



UNIQUE  
CUSTOM DOORS  
EST. 1995

Florida Impact Approval:

FL #11436-R6

FBC VERSION: 2023

Miami Dade County Notice of Acceptance:

NOA #24-0423.01

# Certificate of Independence

Rule 61G20-3 F.A.C. | Report No. 2071-CI, Rev. 4 | Project No. 422-0604 | 6/12/23 | Page 1 of 1

## Product Manufacturer

New Era Door Corp.  
dba Custom Door and Millwork  
2787 N. Airport Rd., Unit No. 410  
Fort Myers, Florida 33907

## Product Name, Model and/or Description

Impact Double Glazed Doors with Transom – Outswing and Inswing  
Impact Double Opaque Entry Door – Outswing and Inswing

**Code:** Current Edition of the Florida Building Code including the 8th Edition (2023) Florida Building Code

**Compliance Method:** Product Approval Rule 61G20-3.009 – Certification of Independence

## **Certificate of Independence per Product Approval Rule 61G20-3.009**

PTC Product Design Group, LLC and Robert J. Amoruso, P.E. does not have, nor will acquire, any financial interest in the company manufacturing or distributing product(s) covered by this Product Evaluation Report.

PTC Product Design Group, LLC and Robert J. Amoruso, P.E. do not have, nor will acquire any financial interest in any other entity involved in the approval process or testing of the product(s) covered by this Product Evaluation Report.

Robert J. Amoruso, P.E.  
FL P.E. License Number 49752



# Equivalency Evaluation Report

Rule 61G20-3 F.A.C. | Report No. 2071-EER, Rev. 4 | Project No. 422-0604 | 6/12/23 | Page 1 of 2

## Product Manufacturer

New Era Door Corp.  
dba Custom Door and Millwork  
2787 N. Airport Rd., Unit No. 410  
Fort Myers, Florida 33907

## Product Name, Model and/or Description

Impact Double Glazed Doors with Transom – Outswing and Inswing  
Impact Double Opaque Entry Door – Outswing and Inswing

**Code:** Current Edition of the Florida Building Code including the 8th Edition (2023) Florida Building Code

**Compliance Methods:** Product Approval Rule 61G20-3.015(5)(d) – Equivalency of Standards

- Impact Double Glazed Doors with Transom – Outswing and Inswing
  - CDM0003, Rev. E, dated 6/12/23 signed and sealed by Robert J. Amoruso, Custom Door and Millworks, Impact Double Glazed O.S. Door with Transom – Outswing and Inswing – Installation Anchorage Details
  - CTLA 1850W-1, dated September 09, 2008
- Impact Double Opaque Entry Door – Outswing and Inswing
  - CDM0004, Rev. E, dated 6/12/23, signed and sealed by Robert J. Amoruso, Custom Door and Millworks, Impact Double Opaque Entry Door – Outswing and Inswing – Installation Anchorage Details
  - CTLA 1850W, dated September 09, 2008

## **Performance Standards (used in testing):**

- ASTM E330-02, Test Method for Structural Performance of Exterior Windows, Curtain Walls, and Doors by Uniform Static Air Pressure Difference.
- ASTM E547-00, Water Penetration of Exterior Windows and Doors by Static Air Pressure Difference.
- ASTM E283-04, Standard Test Method for Determining Rate of Air Leakage Through Exterior Windows, Curtain Walls, and Doors Under Specified Pressure Differences Across the Specimen
- ASTM E1886-05, Standard Test Method for Performance of Exterior Windows, Glazed Curtain Walls, Doors, and Storm Shutters Impacted by Missiles and Exposed to Cyclic Pressure Differentials.
- ASTM E1996-05, Standard Specification for Performance of Exterior Windows, Curtain Walls, Doors, and Storm Shutters Impacted by Windborne Debris in Hurricanes.

## **Equivalency Evaluation:**

The following table shows the performance standards used in testing and those in the current edition of the FBC.

Standard Used in Testing		Current Edition of the Florida Building Code including the 8 <sup>th</sup> Edition (2023) Florida Building Code		Comments
Description	Revision Level	Building Volume (FBC)	Residential Volume (FRC)	
ASTM E330	02	14	14	See Evaluation Below
ASTM E547	00	Not in code	Not in code	
ASTM E283	04	04 (2012)	04 (2012)	
ASTM E1886	05	13a	13a	
ASTM E1996	05	14a	14a	

The AAMA and ASTM Standards listed above and used in testing have been compared to their current revision levels in the 8th Edition (2023) Florida Building Code and found to be acceptable. Changes in the current revisions do not affect the results obtained using previous versions of the reference standard.



# Equivalency Evaluation Report

Rule 61G20-3 F.A.C. | Report No. 2071-EER, Rev. 4 | Project No. 422-0604 | 6/12/23 | Page 2 of 2

ASTM E1996 Testing Evaluation:

- 1) Wind Zone 4 testing
  - a. ASTM E1996-14 moved Wind Zone 4 criteria to the non-mandatory appendix. As indicated in Appendix X4.1, ASTM E1996-14a the Wind Zone 4 requirement, though non-mandatory, is still present and may be specified when needed to meet specific building codes requirements. Those requirements are detailed in Sections 1609.1.2.2, 1609.1.2.4 and 1609.3 of the Florida Building Code. Based on a review of the test reports, those parameters are met.
- 2) The Missile Level and Impact Speed used in testing are consistent with those currently required by the Florida Building Code and ASTM E11996.
- 3) The static load (ASTM E330) and cyclic load (ASTM E1886/E1996) parameters used in testing are consistent with those currently required by the Florida Building Code.

## **Certificate of Independence per Product Approval Rule 61G20-3.009**

PTC Product Design Group, LLC and Robert J. Amoruso, P.E. does not have, nor will acquire, any financial interest in the company manufacturing or distributing product(s) covered by this Product Evaluation Report. PTC Product Design Group, LLC and Robert J. Amoruso, P.E. do not have, nor will acquire any financial interest in any other entity involved in the approval process or testing of the product(s) covered by this Product Evaluation Report.

Evaluated by:  
Robert J. Amoruso, P.E.  
FL PE License No. 49752



# Product Evaluation Report

Rule 61G20-3 F.A.C. | Report No. 2071-PER, Rev. 4 | Project No. 422-0604 | 6/12/23 | Page 1 of 2

## Product Manufacturer

New Era Door Corp.  
dba Custom Door and Millwork  
2787 N. Airport Rd., Unit No. 410  
Fort Myers, Florida 33907

## Product Name, Model and/or Description

Impact Double Glazed Door with Transom – Outswing and Inswing  
Impact Double Opaque Entry Door – Outswing and Inswing

**Code:** Current Edition of the Florida Building Code including the 8th Edition (2023) Florida Building Code

**Compliance Method:** Product Approval Rule 61G20-3.005(1)(d) – Product Evaluation Report by a Licensed Professional Engineer

### **Product Name, Model and/or Designation; Test Report No.; and Installation Drawing No.:**

- Impact Double Glazed Doors with Transom – Outswing and Inswing
  - CDM0003, Rev. E, dated 6/12/23 signed and sealed by Robert J. Amoruso, Custom Door and Millworks, Impact Double Glazed O.S. Door with Transom – Outswing and Inswing – Installation Anchorage Details
  - CTLA 1850W-1, dated September 09, 2008
- Impact Double Opaque Entry Door – Outswing and Inswing
  - CDM0004, Rev. E, dated 6/12/23, signed and sealed by Robert J. Amoruso, Custom Door and Millworks, Impact Double Opaque Entry Door – Outswing and Inswing – Installation Anchorage Details
  - CTLA 1850W, dated September 09, 2008

### **Component Approvals:**

- Laminate Glass Interlayer: Uvekol Laminated Glass Interlayer by Allnex USA Inc. per current Miami-Dade Notice of Acceptance found [here](#).

### **Engineering Analysis & Evaluation:**

- Anchorage engineering (Report No. 1133-Calc & 1119-Calc) in accordance with the current edition of the Florida Building Code, signed and sealed by Robert J. Amoruso, P.E., FL License Number 49752.
- Report No. 2568, Rev. 1, dated 6/12/23, signed and sealed by Robert J. Amoruso, P.E. FL No. 49752, Title: Product Evaluation of Door Lock Component Interchangeability to Custom Door & Millworks Wood Entry Doors
  - Von Duprin (Allegion) WS9827/9927 and/or WS9857/9957 Multi-Point exit device can be used as a replacement for the Emtek 8450 Cylinder Lock with single cylinder dead bolt & steel surface bolts with strike plates used in testing.
- Report No. 2597, Rev. 1, dated 6/12/23, signed and sealed by Robert J. Amoruso, P.E. FL No. 49752, Title: Product Evaluation of Custom Door & Millwork Inswing Wood Entry Doors
- Window glazing verified using ASTM E1300-12AE1 and ASTM E1300-2016

### **Performance Standards (used in testing):**

- ASTM E330-02, Test Method for Structural Performance of Exterior Windows, Curtain Walls, and Doors by Uniform Static Air Pressure Difference.
- ASTM E547-00, Water Penetration of Exterior Windows and Doors by Static Air Pressure Difference.
- ASTM E283-04, Standard Test Method for Determining Rate of Air Leakage Through Exterior Windows, Curtain Walls, and Doors Under Specified Pressure Differences Across the Specimen
- ASTM E1886-05, Standard Test Method for Performance of Exterior Windows, Glazed Curtain Walls, Doors and Storm Shutters Impacted by Missiles and Exposed to Cyclic Pressure Differentials.
- ASTM E1996-05, Standard Specification for Performance of Exterior Windows, Curtain Walls, Doors and Storm Shutters Impacted by Windborne Debris in Hurricanes.



# Product Evaluation Report

Rule 61G20-3 F.A.C. | Report No. 2071-PER, Rev. 4 | Project No. 422-0604 | 6/12/23 | Page 2 of 2

## Limitations & Conditions of Use:

- The following product has been evaluated for outside the High Velocity Hurricane Zone (HVHZ).
  - Impact Double Glazed Doors with Transom – Outswing and Inswing
  - Impact Double Opaque Entry Door – Outswing and Inswing
- The following product will not require an approved impact protective system when used in wind borne debris regions including the HVHZ.
  - Impact Double Glazed Doors with Transom – Outswing and Inswing
  - Impact Double Opaque Entry Door – Outswing and Inswing
- Refer to Product Installation Instructions noted above for:
  - Maximum allowable wind loads at related maximum allowable size(s).
  - Overall dimensions and material/grade of main product components, accessories, etc.
  - Illustrated diagrams of the attachment of the product to substrate structure.
  - Anchor type(s), size(s), substrate(s), embedment, edge distance, and spacing/locations.
- Site wind pressures shall be determined by a licensed professional engineer in accordance with the current edition of the Florida Building Code (and/or ASCE 7 as referenced in the current edition of the Florida Building Code) for components and cladding based on allowable stress design.
- Site conditions not covered in this product evaluation document are subject to additional engineering analysis by a licensed professional engineer or registered architect as required by the authority having jurisdiction.
- Adequacy of the existing structural substrates as a main wind force resisting system capable of withstanding and transferring applied product loads to the foundation is the responsibility of the licensed professional engineer or registered architect acting as the design professional of record for the project of installation.

### Certificate of Independence per Product Approval Rule 61G20-3.009

PTC Product Design Group, LLC and Robert J. Amoruso, P.E. does not have, nor will acquire, any financial interest in the company manufacturing or distributing product(s) covered by this Product Evaluation Report.

PTC Product Design Group, LLC and Robert J. Amoruso, P.E. do not have, nor will acquire any financial interest in any other entity involved in the approval process or testing of the product(s) covered by this Product Evaluation Report.

Evaluated By:  
Robert J. Amoruso, P.E.  
FL P.E. License Number 49752



# **CERTIFICATION OF PARTICIPATION**

**National Accreditation and Management Institute, Inc.  
confirms that:**

**New Erra Doors, LLC dba Custom Door and Millwork  
2787 N. Airport Road #410  
Fort Myers, Florida 33907**

**Participates within a Quality Assurance Program  
that complies with ISO/IEC 17020 and Guide 53**

**New Erra Doors, LLC dba Custom Door and Millwork's  
Quality Assurance ID # 1345-1**

**Quality Assurance Program for products  
manufactured or assembled at referenced location.**



---

**Thomas D. Wix, Quality Assurance Manager**

**Certificate Valid From 9/17/2024 to 12/31/2025**

**The NAMI Program is recognized as an approved quality assurance entity  
within the State of Florida # QUA1789.**

# NOTICE OF PRODUCT CERTIFICATION



CERTIFICATION NO: NI009646-R10  
DATE: 10/02/2008  
CERTIFICATION PROGRAM: Structural  
COMPANY: New Erra  
CODE: 1345-1  
REVISION DATE: 12/09/2024

This certification represents product conformity to the applicable specification and that certification criteria has been satisfied. A NAMI approved certification label must be applied to the product to claim certification status. To affirm the certification status, please visit [www.namicertification.com](http://www.namicertification.com). NAMI is accredited to the ISO/IEC 17065 by the Standards Council of Canada (SCC).

COMPANY NAME AND ADDRESS	PRODUCT DESCRIPTION
<b>New Erra Doors, LLC</b> <b>dba Custom Door &amp; Millworks</b> <b>2787 N. Airport Road, #410</b> <b>Fort Myers, FL 33907</b>	<b>“Mara Macho” Mahogany Out-Swing</b> <b>Double Glazed Entry Door</b> <b>w/Arch Transom</b>  One Active Panel/One Inactive Panel w/Fixed Transom  Configuration: O/XX Glazing: Monolithic Laminate - 1/4" Tempered Glass/ 0.100" Uvekool PVB Interlayer/1/4" Heat Strengthened Glass  Frame:       W-6'3"               H-13'4" Panel:       W-3'0"               H-10'0" Transom:     W-6'3"               H-3'2"

SPECIFICATION	PRODUCT RATING
<b>ASTM E283-04/E330-02/E547-00</b> <b>ASTM E1886-05/E1996-05</b>	<b>Design Pressure: +55/-55 psf</b> <b>Wind Zone 4 - Missile Level D</b>

Product Tested By: Certified Testing Laboratories  
Report No: CTLA-1850W-1  
Expiration Date: September 30, 2025

Administrator's Signature: \_\_\_\_\_ 

## NATIONAL ACCREDITATION AND MANAGEMENT INSTITUTE, INC.

4794 George Washington Memorial Highway  
Hayes, VA 23072  
Tel: (804) 684-5124

Email: [nami@namiinc.com](mailto:nami@namiinc.com)



# NEW ERRA DOORS CORP, dba CUSTOM DOOR AND MILLWORK

## IMPACT DOUBLE GLAZED DOORS W/ TRANSOM

### OUTSWING AND INSWING

### INSTALLATION ANCHORAGE DETAILS

**GENERAL NOTES:**

1. THE PRODUCT SHOWN HEREIN IS DESIGNED TO COMPLY WITH THE CURRENT EDITION OF THE FLORIDA BUILDING CODE, BUILDING AND RESIDENTIAL VOLUMES EXCLUDING THE HIGH VELOCITY HURRICANE ZONE (HVHZ) AT THE DESIGN PRESSURES STATED HEREIN.
2. THE PRODUCT DETAILS CONTAINED HEREIN ARE BASED UPON SIGNED AND SEALED TEST REPORT(S) NO. CTLA 1850W-1 AND ASSOCIATED LABORATORY DRAWINGS.
3. ADEQUACY OF THE EXISTING STRUCTURAL CONCRETE / MASONRY AND 2X FRAMING AS A MAIN WIND FORCE RESISTING SYSTEM CAPABLE OF WITHSTANDING AND TRANSFERRING APPLIED PRODUCT LOADS TO THE STRUCTURE IS THE RESPONSIBILITY OF THE ENGINEER OR ARCHITECT OF RECORD.
4. 1X AND 2X BUCKS (WHEN USED) SHALL BE DESIGNED AND ANCHORED TO PROPERLY TRANSFER ALL LOADS TO THE STRUCTURE. BUCK DESIGN AND INSTALLATION IS THE RESPONSIBILITY OF THE ENGINEER OR ARCHITECT OF RECORD.
5. THIS PRODUCT DOES NOT REQUIRE AN IMPACT PROTECTIVE SYSTEM THAT COMPLIES WITH THE CURRENT EDITION OF THE FLORIDA BUILDING CODE, BUILDING AND RESIDENTIAL VOLUMES IN THE WIND BORNE DEBRIS REGION. THE PRODUCT IS IMPACT-RESISTANT TO WIND ZONE 4, MISSILE LEVEL D.
6. DOOR FRAME AND PANEL MATERIAL: MAHOGANY.
7. GLASS MEETS THE REQUIREMENTS OF ASTM E1300-12AE1 & ASTM E1300-2016. SEE SHEET 6 OR 7 FOR GLAZING DETAIL.
8. DESIGNATION "X" STANDS FOR OPERABLE PANEL - SEE ELEVATION ON SHEET 2.
9. HARDWARE TESTED:
  - 9.1 EMTEK 8450 CYLINDER LOCK WITH SINGLE CYLINDER DEAD BOLT.
  - 9.2 STEEL SURFACE BOLTS WITH STRIKE PLATES. TWO HANDLE STYLES SHOWN FOR OUTSWING VS. INSWING. OTHER STYLES ACCEPTABLE.

**INSTALLATION NOTES:**

1. ONE (1) INSTALLATION ANCHOR IS REQUIRED AT EACH ANCHOR LOCATION SHOWN.
2. THE INSTALLATION ANCHOR SPACING DEPICTED DICTATES THE MINIMUM NUMBER OF ANCHORS TO BE USED FOR PRODUCT INSTALLATION. ANCHORS ARE TO MATCH TYPE, SIZE, AND EMBEDMENT OF THOSE SHOWN HEREIN FOR RESPECTIVE SUBSTRATE.
3. SHIM AS REQUIRED AT EACH INSTALLATION ANCHOR WITH LOAD BEARING SHIM(S). MAXIMUM ALLOWABLE SHIM SIZE IS 1/4 INCH. SHIM WHERE SPACE OF 1/16 INCH OR GREATER OCCURS. SHIM(S) SHALL BE CONSTRUCTED OF HIGH DENSITY PLASTIC OR BETTER.
4. FOR INSTALLATION INTO WOOD FRAMING, USE #12 WOOD SCREWS OF SUFFICIENT LENGTH TO ACHIEVE 1 1/2 INCH MINIMUM EMBEDMENT. MINIMUM EDGE DISTANCE SHALL BE 7/8 INCH TO EDGE OF SUPPORTING WOOD SUBSTRATE.
5. FOR INSTALLATION THROUGH 1X BUCK TO CONCRETE / MASONRY, OR DIRECTLY INTO CONCRETE / MASONRY, USE 3/16 INCH ITW TAPCONS (ADVANCED THREADFORM TYPE) OF SUFFICIENT LENGTH TO ACHIEVE 1 1/2 INCH MINIMUM EMBEDMENT INTO CONCRETE AND 1 INCH MINIMUM EMBEDMENT INTO MASONRY (CMU). MINIMUM EDGE DISTANCES SHALL BE 1-1/8 INCH IN CONCRETE AND 2 INCHES INTO MASONRY (CMU).
6. ALTERNATE CONCRETE / MASONRY / WOOD INSTALLATION ANCHORS OF EQUIVALENT PERFORMANCE CHARACTERISTICS CAN BE USED UPON APPROVAL BY THE ARCHITECT OR ENGINEER OF RECORD.
7. MINIMUM EMBEDMENT AND EDGE DISTANCE EXCLUDE WALL FINISHES (INCLUDING BUT NOT LIMITED TO STUCCO, FOAM, BRICK VENEER, AND SIDING).
8. INSTALLATION ANCHORS AND ASSOCIATED HARDWARE MUST BE MADE OF CORROSION RESISTANT MATERIAL OR HAVE A CORROSION RESISTANT COATING DISSIMILAR METALS OR MATERIALS IN CONTACT WITH PRESSURE TREATED WOOD MUST BE PROTECTED TO PREVENT REACTION.
9. FOR HOLLOW BLOCK AND GROUT FILLED BLOCK, DO NOT INSTALL INSTALLATION ANCHORS INTO MORTAR JOINTS. EDGE DISTANCE IS MEASURED FROM FREE EDGE OF BLOCK OR EDGE OF MORTAR JOINT INTO FACE SHELL OF BLOCK.
10. INSTALLATION ANCHORS SHALL BE INSTALLED IN ACCORDANCE WITH ANCHOR MANUFACTURER'S INSTALLATION INSTRUCTIONS AND ANCHORS SHALL NOT BE USED IN SUBSTRATES WITH STRENGTHS LESS THAN THE MINIMUM STRENGTH SPECIFIED BY THE ANCHOR MANUFACTURER AND/OR AS REQUIRED BELOW IN NOTE 11.
11. INSTALLATION ANCHOR CAPACITIES FOR PRODUCTS HEREIN ARE BASED ON SUBSTRATE MATERIALS WITH THE FOLLOWING PROPERTIES:
  - 11.1. WOOD - MINIMUM SPECIFIC GRAVITY OF 0.42.
  - 11.2. CONCRETE - MINIMUM COMPRESSIVE STRENGTH OF 2500 psi
  - 11.3. MASONRY - STRENGTH CONFORMANCE TO ASTM C-90, MEDIUM WEIGHT WITH DENSITY > 117 PCF.

PERFORMANCE RATING			
CONFIGURATION	DESIGN PRESSURE RATING	IMPACT RATING	WATER PENETRATION RATING
OUTSWING	+/-55 PSF	WIND ZONE 4 MISSILE LEVEL D	YES (Note 1)
INSWING	+/-55 PSF	WIND ZONE 4 MISSILE LEVEL D	NONE (Note 2)

**WATER PENETRATION TESTING NOTES**

1) OUTSWING CONFIGURATION TESTED FOR WATER PENETRATION IN ACCORDANCE WITH ASTM E547. THEREFORE, INSTALLATION APPROVED FOR ALL LOCATIONS WHERE WATER PENETRATION RESISTANCE IS REQUIRED.

2) INSWING CONFIGURATION NOT TESTED FOR WATER PENETRATION IN ACCORDANCE WITH ASTM E547. THEREFORE, INSTALLATION APPROVED ONLY FOR LOCATIONS WHERE WATER PENETRATION RESISTANCE IS NOT REQUIRED OR WHERE A OVERHANG MEETING THE REQUIREMENTS OF THE FBC HAVE BEEN MET. SEE BELOW FOR OVERHANG REQUIREMENTS.

In accordance with 8th Edition (2023) Florida Building Code Section 1709.5.2, Exception 1 & 2 & 8th Edition (2023) Florida Residential Code Section R609.3, Exception 1 & 2.  
 Door assemblies may be installed where the overhang (OH) ratio is equal to or more than 1 need not be tested for water infiltration.  
 The overhang ratio shall be calculated by the following equation:  
 OH ratio = OH Length/OH Height  
 where:  
 OH Length = The horizontal measure of how far an overhang over a door projects out from the door's surface.  
 OH Height = The vertical measure of the distance from the door's sill to the bottom of the overhang over a door.

DRAWING SHEET INDEX	
SHEET	DESCRIPTION
1	GENERAL AND INSTALLATION NOTES
2	ELEVATION AND ANCHOR LAYOUT
3	ADDITIONAL APPROVED CONFIGURATIONS
4	OUTSWING INSTALLATION - VERTICAL SECTIONS
5	INSWING INSTALLATION - VERTICAL SECTIONS
6	OUTSWING INSTALLATION - HORIZONTAL SECTIONS - GLAZING DETAIL
7	INSWING INSTALLATION - HORIZONTAL SECTIONS - GLAZING DETAIL

**NEW ERRA DOORS CORP, dba CUSTOM DOOR & MILLWORK**  
 2787 N. AIRPORT RD., UNIT NO. 410  
 FORT MYERS, FLORIDA 33907

**PTC**

PTC PRODUCT DESIGN GROUP, LLC  
 PO BOX 520775  
 LONGWOOD, FLORIDA 32752  
 FBPE C.A. NO. 25535  
 Phone: 321.690.1788  
 Fax: 321.690.1789  
 Email: info@ptc-corp.com

TITLE: IMPACT DOUBLE GLAZED DOORS W/TRANSOM, O/S & I/S  
 GENERAL AND INSTALLATION NOTES

PREPARED BY: BB  
 DRAWN BY: BB  
 DATE: 09/25/08  
 SCALE: N.T.S.  
 DRAWING NO.: CDM0003  
 REV: E  
 SHEET: 1 OF 7

Robert J. Amoruso, P.E.  
 FL P.E. No. 49752

PROJECT #422-0604			
E	UPDATE TO 8TH EDITION (2023) FBC	6/12/23	RJA
D	UPDATE TO 7TH EDITION (2020) FBC	01/24/21	RJA
REV	DESCRIPTION	DATE	BY

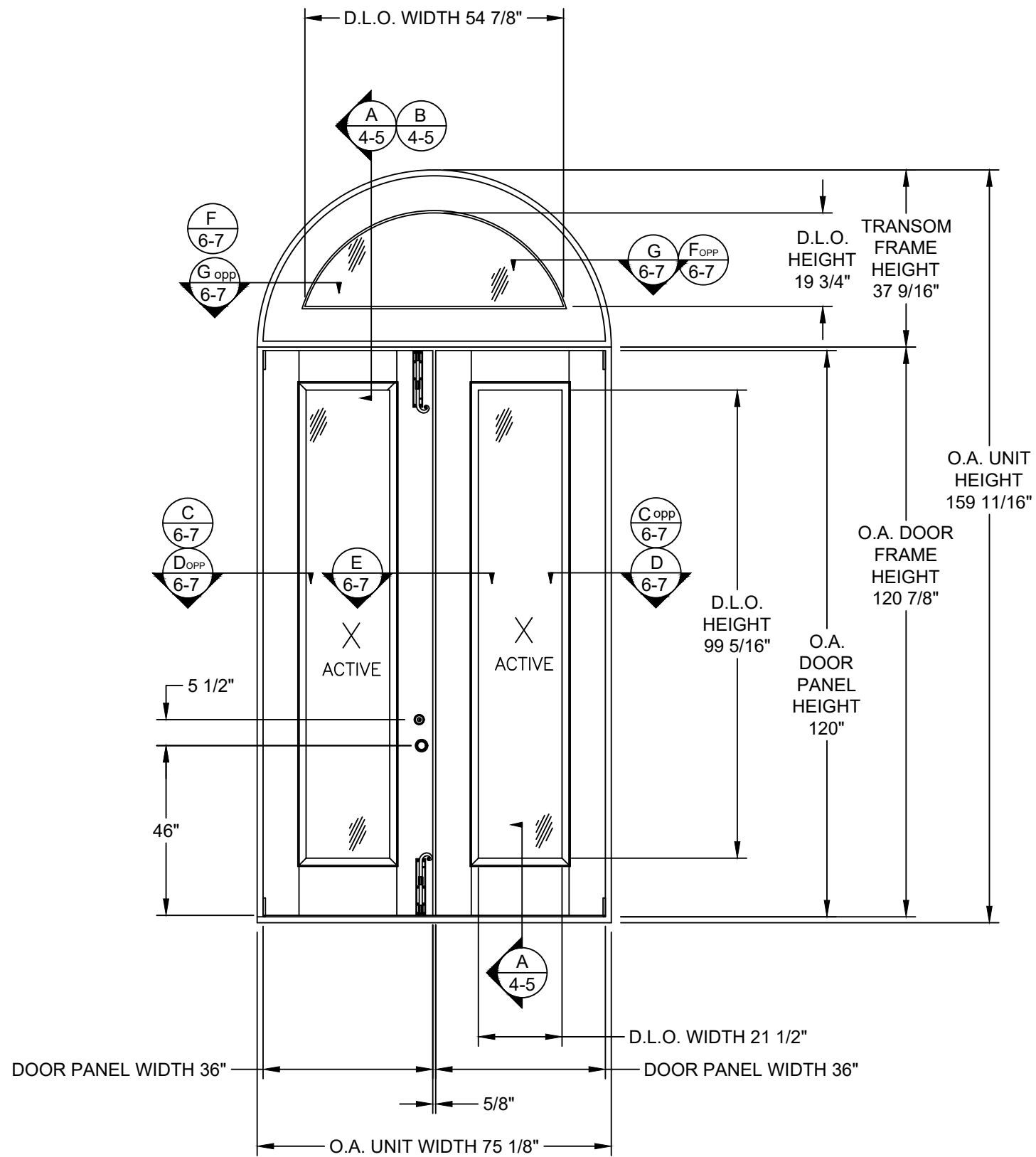

**ELEVATION**  
DOUBLE DOOR W/ TRANSOM  
INTERIOR VIEW

**OUTSWING ELEVATION SHOWN**  
**INSWING SIMILAR**

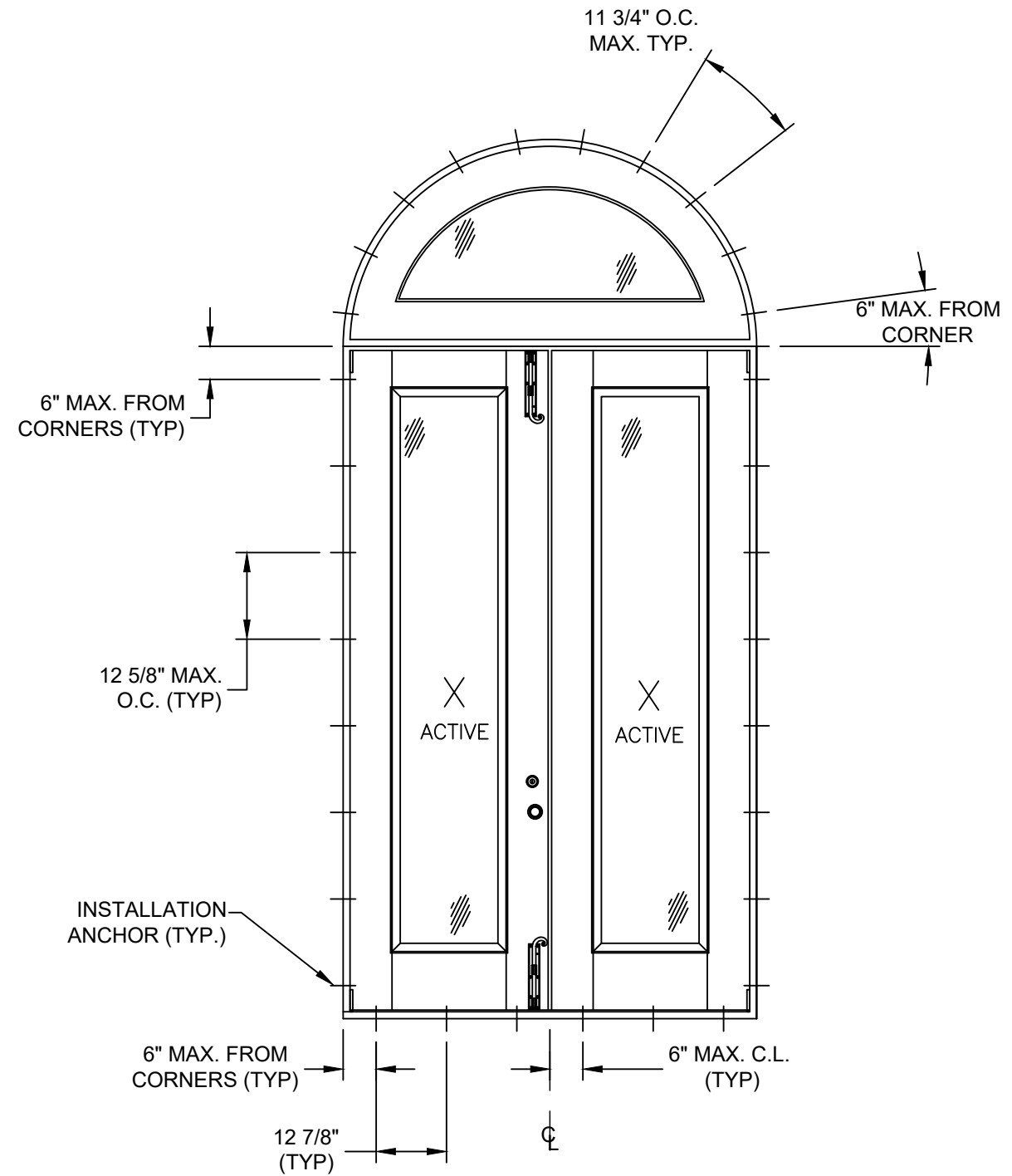

**ANCHOR LAYOUT**  
DOUBLE DOOR W/ TRANSOM  
INTERIOR VIEW

**PROJECT #422-0604**

REV	DESCRIPTION	DATE	BY
E	UPDATE TO 8TH EDITION (2023) FBC	6/12/23	RJA
D	UPDATE TO 7TH EDITION (2020) FBC	01/24/21	RJA

**NEW ERRA DOORS CORP, dba CUSTOM DOOR & MILLWORK**  
2787 N. AIRPORT RD., UNIT NO. 410  
FORT MYERS, FLORIDA 33907

**TITLE: IMPACT DOUBLE GLAZED DOORS W/TRANSOM, O/S & I/S ELEVATION AND ANCHOR LAYOUT**

DATE:	09/25/08
DRAWN BY:	BB
SCALE:	N.T.S.
DRAWING NO.:	CDM0003
REV:	E
SHEET:	2 OF 7

PTC PRODUCT DESIGN GROUP, LLC  
PO BOX 520775  
LONG BEACH, CA 90805  
Phone: 321.690.1788  
Fax: 321.690.1789  
Email: info@ptc-corp.com

Robert J. Amoruso, P.E.  
FL P.E. No. 49752

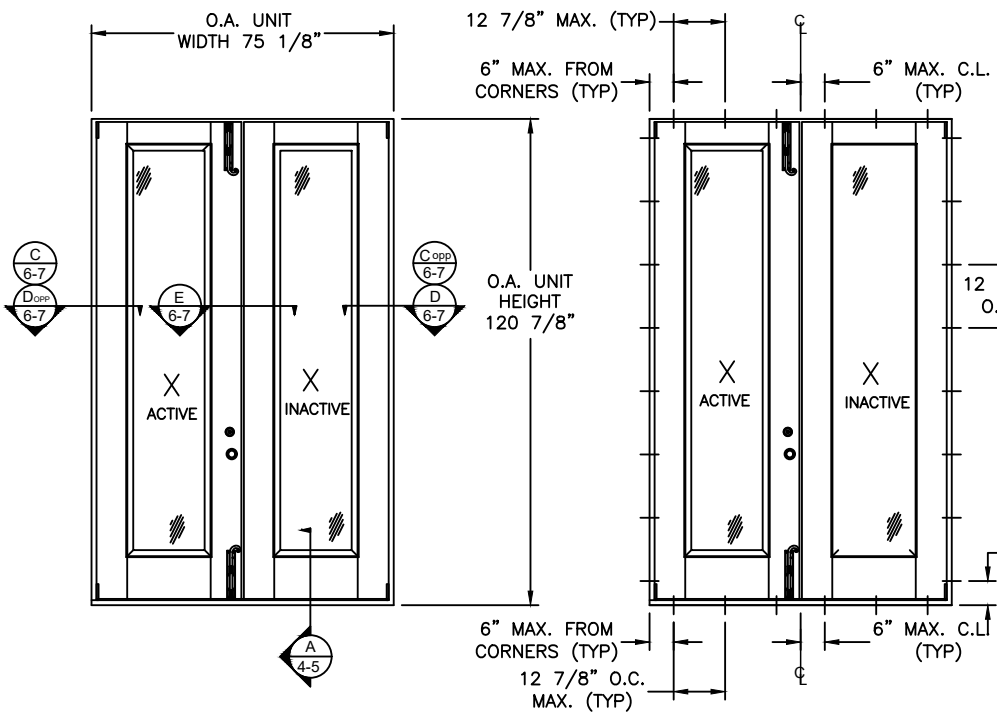

**ELEVATION**  
DOUBLE DOORS W/ O TRANSOM  
INTERIOR VIEW

**ANCHOR LAYOUT**  
DOUBLE DOORS W/ O TRANSOM  
INTERIOR VIEW

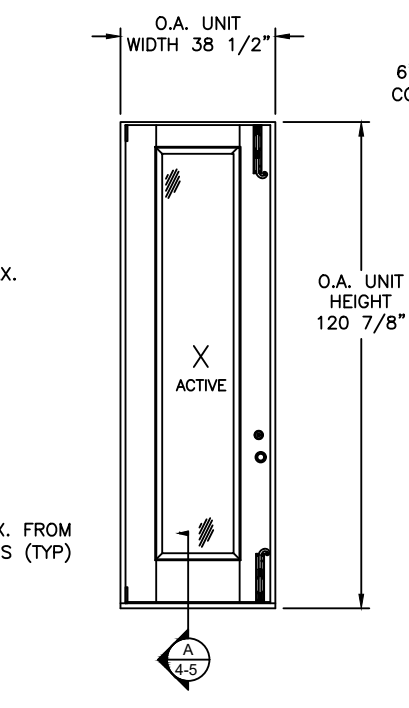

**ELEVATION**  
SINGLE DOOR W/ O TRANSOM  
INTERIOR VIEW

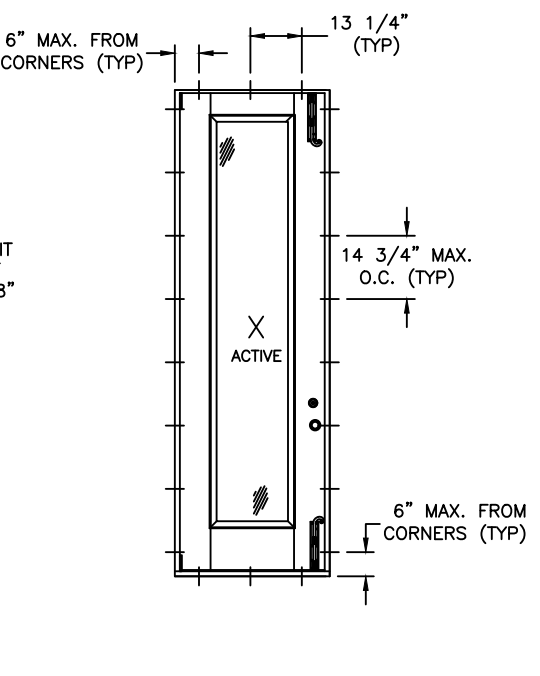

**ANCHOR LAYOUT**  
SINGLE DOOR W/ O TRANSOM  
INTERIOR VIEW

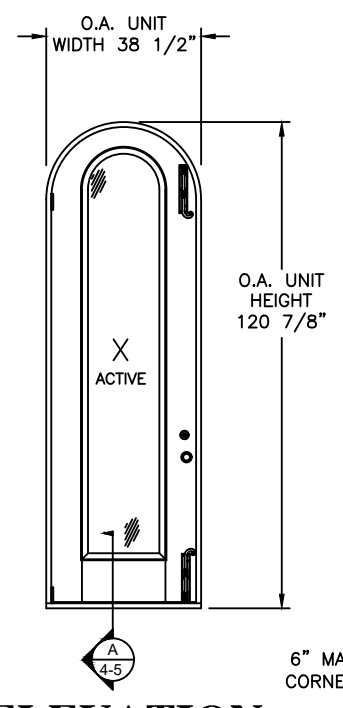

**ELEVATION**  
SINGLE ARCH TOP DOOR W/ O TRANSOM  
INTERIOR VIEW

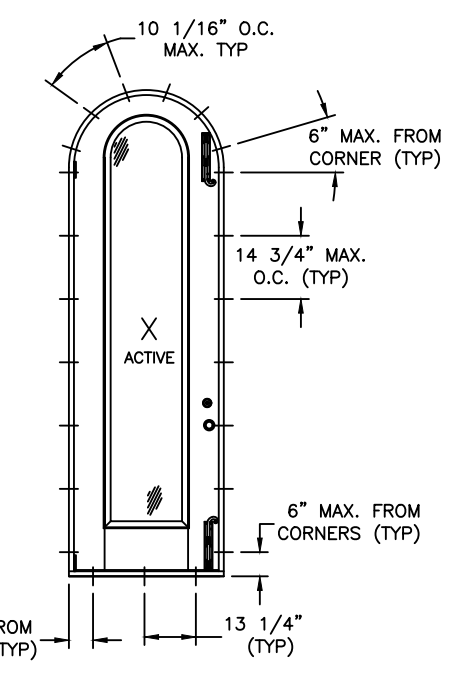

**ANCHOR LAYOUT**  
SINGLE ARCH TOP DOOR W/ O TRANSOM  
INTERIOR VIEW

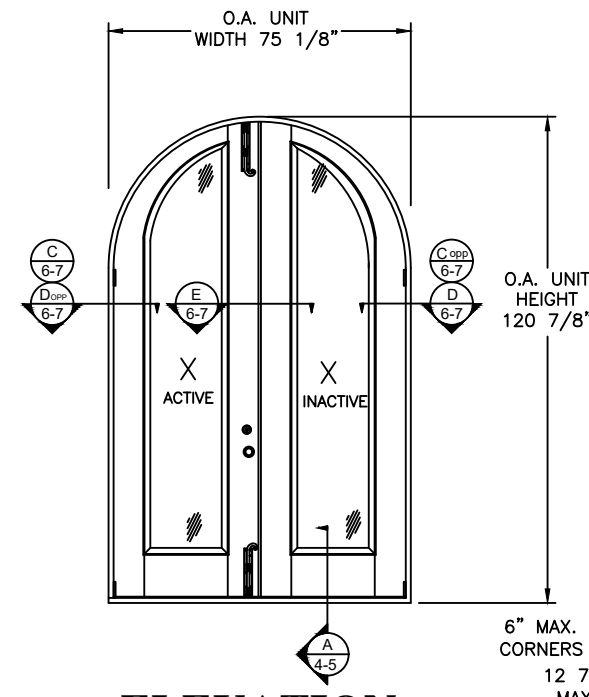

**ELEVATION**  
DOUBLE ARCH TOP DOORS W/ OUT TRANSOM  
INTERIOR VIEW

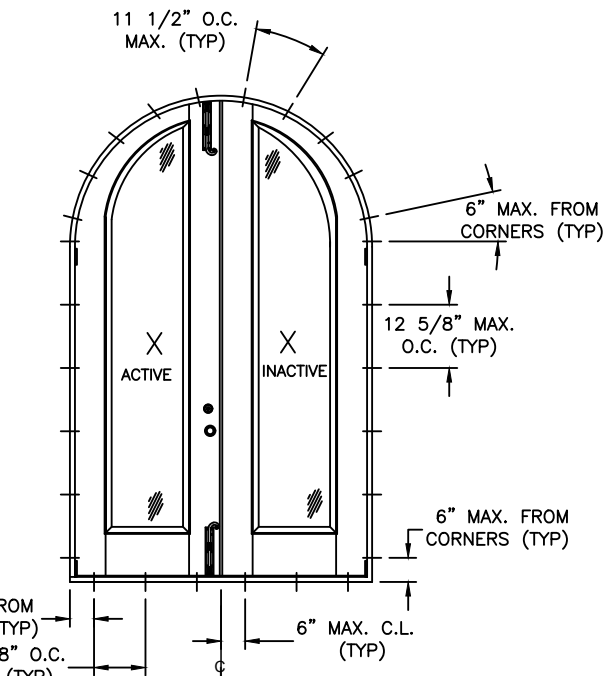

**ANCHOR LAYOUT**  
DOUBLE ARCH TOP DOORS W/ OUT TRANSOM  
INTERIOR VIEW

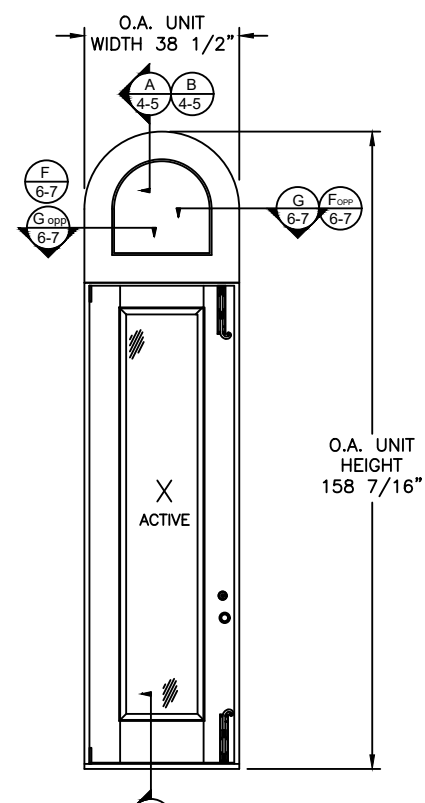

**ELEVATION**  
SINGLE DOOR W/ TRANSOM  
INTERIOR VIEW

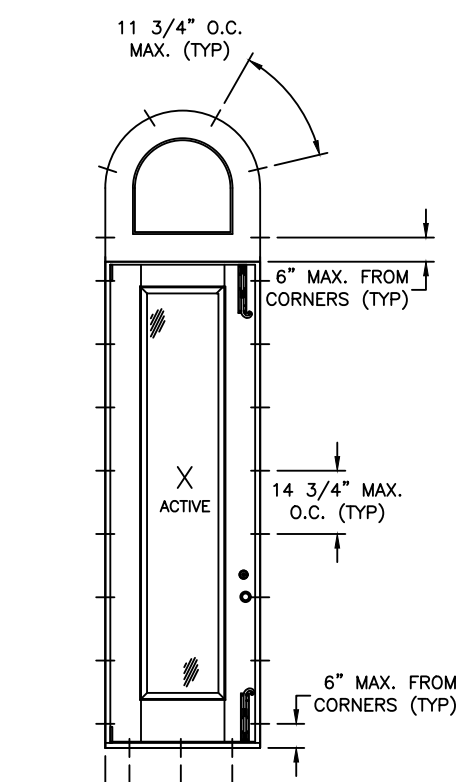

**ANCHOR LAYOUT**  
SINGLE DOORS W/ TRANSOM  
INTERIOR VIEW

**PROJECT #422-0604**

		RJA	BY
	6/12/23	RJA	DATE
E	UPDATE TO 8TH EDITION (2023) FBC		DESCRIPTION
D	UPDATE TO 7TH EDITION (2020) FBC		REV

**NEW ERA DOORS CORP, dba CUSTOM DOOR & MILLWORK**  
2787 N. AIRPORT RD., UNIT NO. 410  
FORT MYERS, FLORIDA 33907

**TITLE: IMPACT DOUBLE GLAZED DOORS W/TRANSOM, O/S & I/S**  
**ADDITIONAL APPROVED CONFIGURATIONS**

PREPARED BY: BB  
SCALE: N.T.S.  
REV: E

DATE: 09/25/08  
DRAWING NO: CDM0003  
SHEET: 3 OF 7

PTC PRODUCT DESIGN GROUP, LLC  
PO BOX 520775  
LONG BEACH, CA 90805  
Phone: 321.690.1788  
Fax: 321.690.1789  
Email: info@ptc-corp.com

Robert J. Amoruso, P.E.  
FL P.E. No. 49752

# OUTSWING INSTALLATION VERTICAL SECTION VIEWS

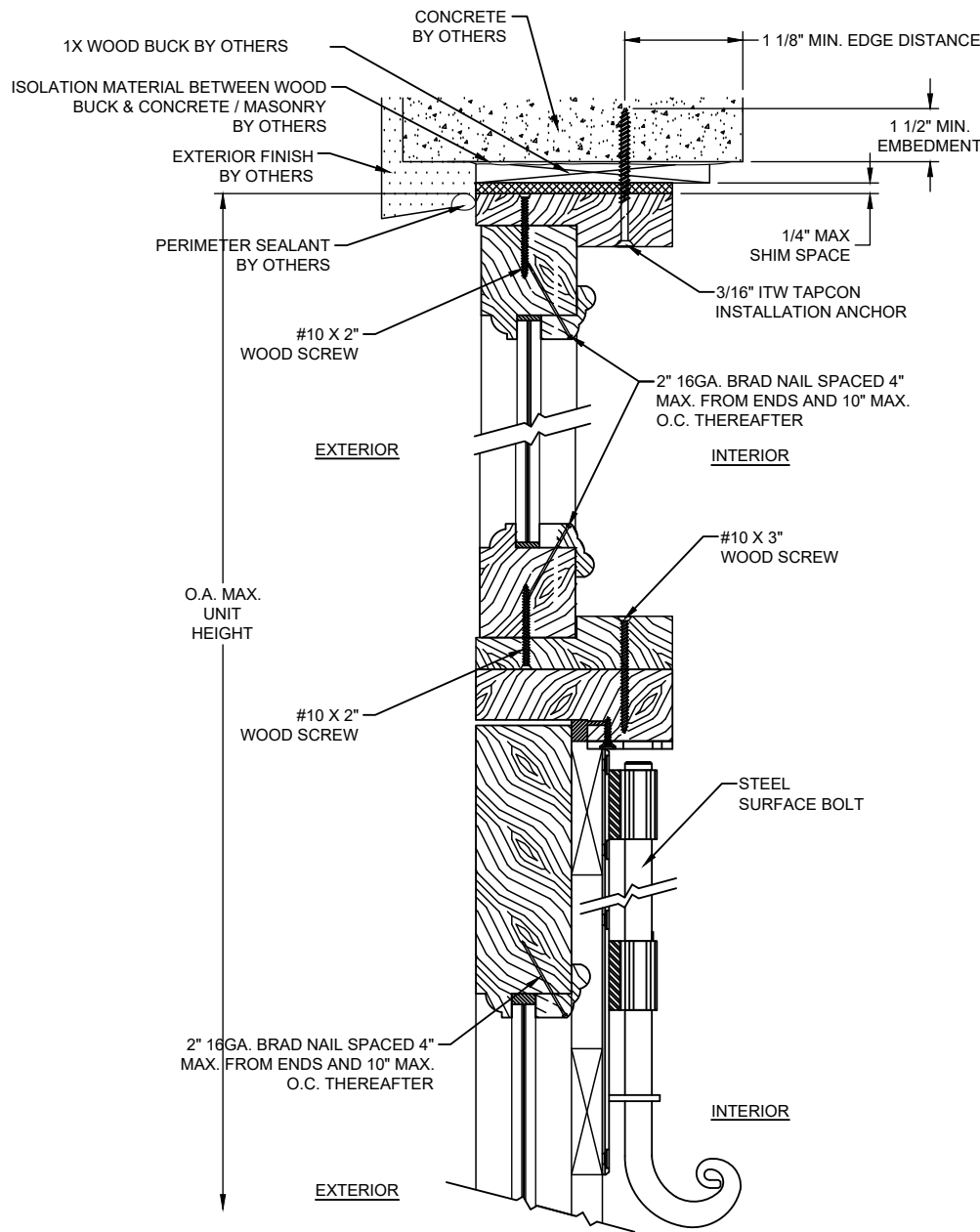

**A** VERTICAL SECTION  
CONCRETE / MASONRY SUBSTRATE

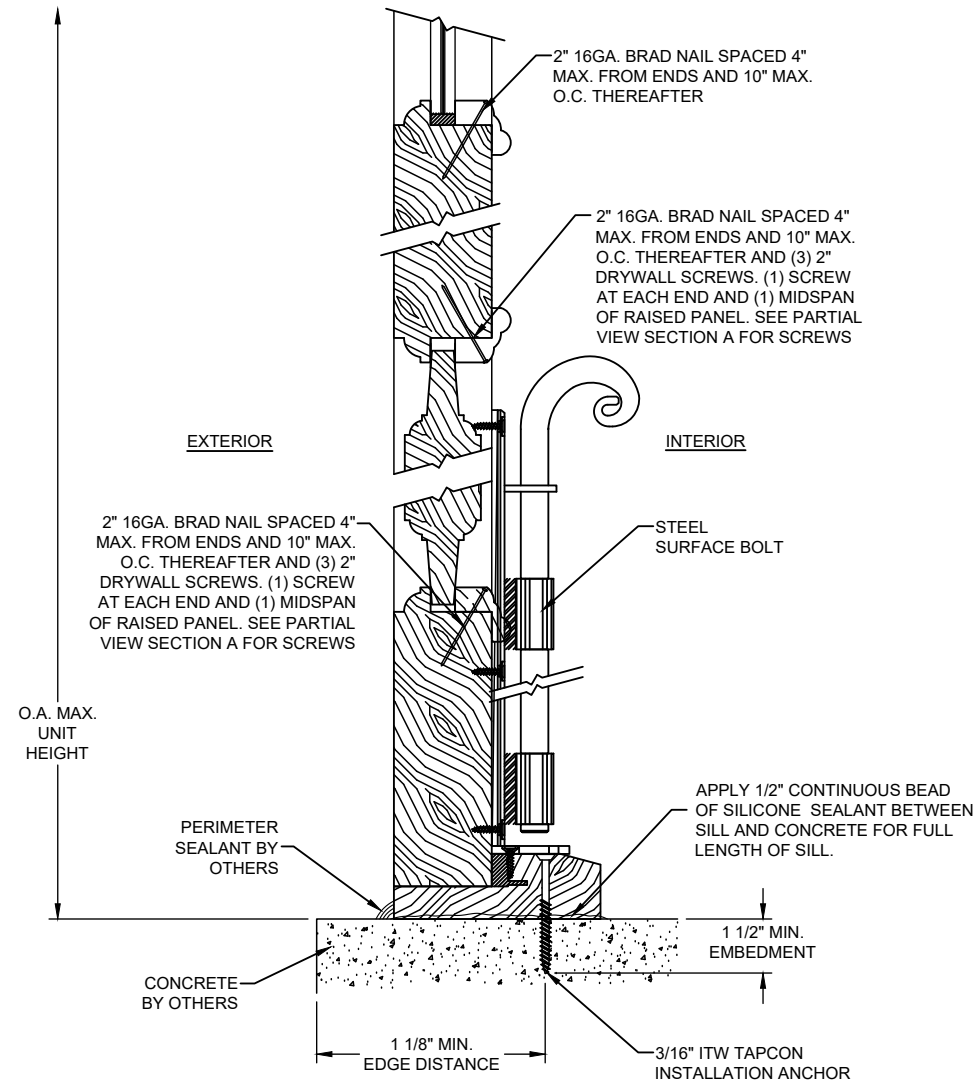

**A** VERTICAL SECTION  
CONCRETE / MASONRY SUBSTRATE

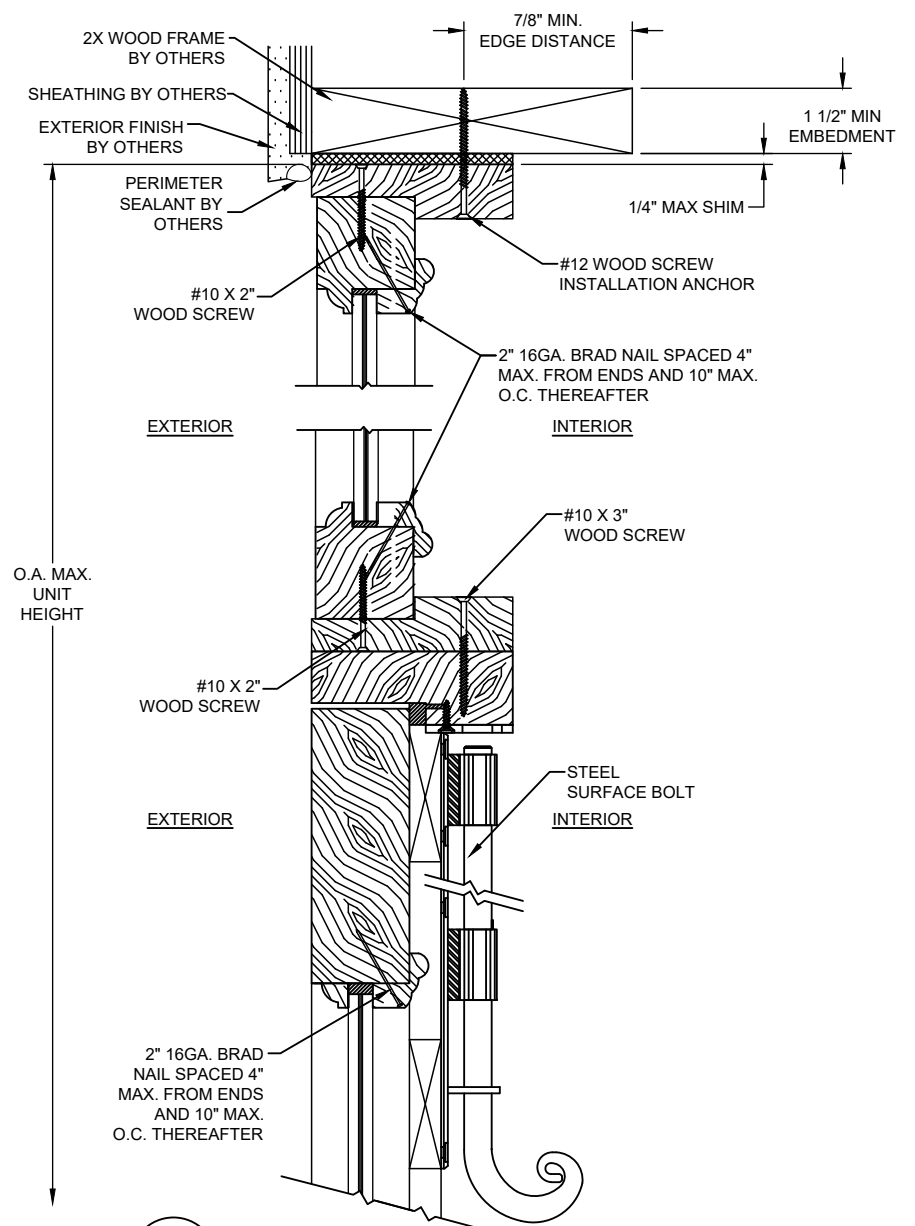

**B** VERTICAL SECTION  
WOOD FRAME SUBSTRATE

PROJECT #422-0604

DATE	DESCRIPTION	REV
6/12/23	UPDATE TO 8TH EDITION (2023) FBC	E
01/24/21	UPDATE TO 7TH EDITION (2020) FBC	D
		RJA
		RJA
		BY

**NEW ERRA DOORS CORP, dba CUSTOM DOOR & MILLWORK**  
2787 N. AIRPORT RD., UNIT NO. 410  
FORT MYERS, FLORIDA 33907

TITLE: IMPACT DOUBLE GLAZED DOORS W/TRANSOM O/S & I/S  
OUTSWING INSTALLATION - VERTICAL SECTIONS

DATE:	09/25/08
DRAWING NO.:	CDM0003
SCALE:	N.T.S.
REV:	E
SHEET:	4 OF 7

PREPARED BY: BB  
DRAWN BY: BB  
CHECKED BY: N.T.S.  
DATE: 09/25/08

PTC PRODUCT DESIGN GROUP, LLC  
PO BOX 520775  
LONGWOOD, FLORIDA 32752  
PHONE: 321.660.1788  
FAX: 321.660.1789  
EMAIL: info@ptc-corp.com  
FBIPE CA. NO. 25935

Robert J. Amoruso, P.E.  
FL P.E. No. 49752

# INSWING INSTALLATION VERTICAL SECTION VIEWS

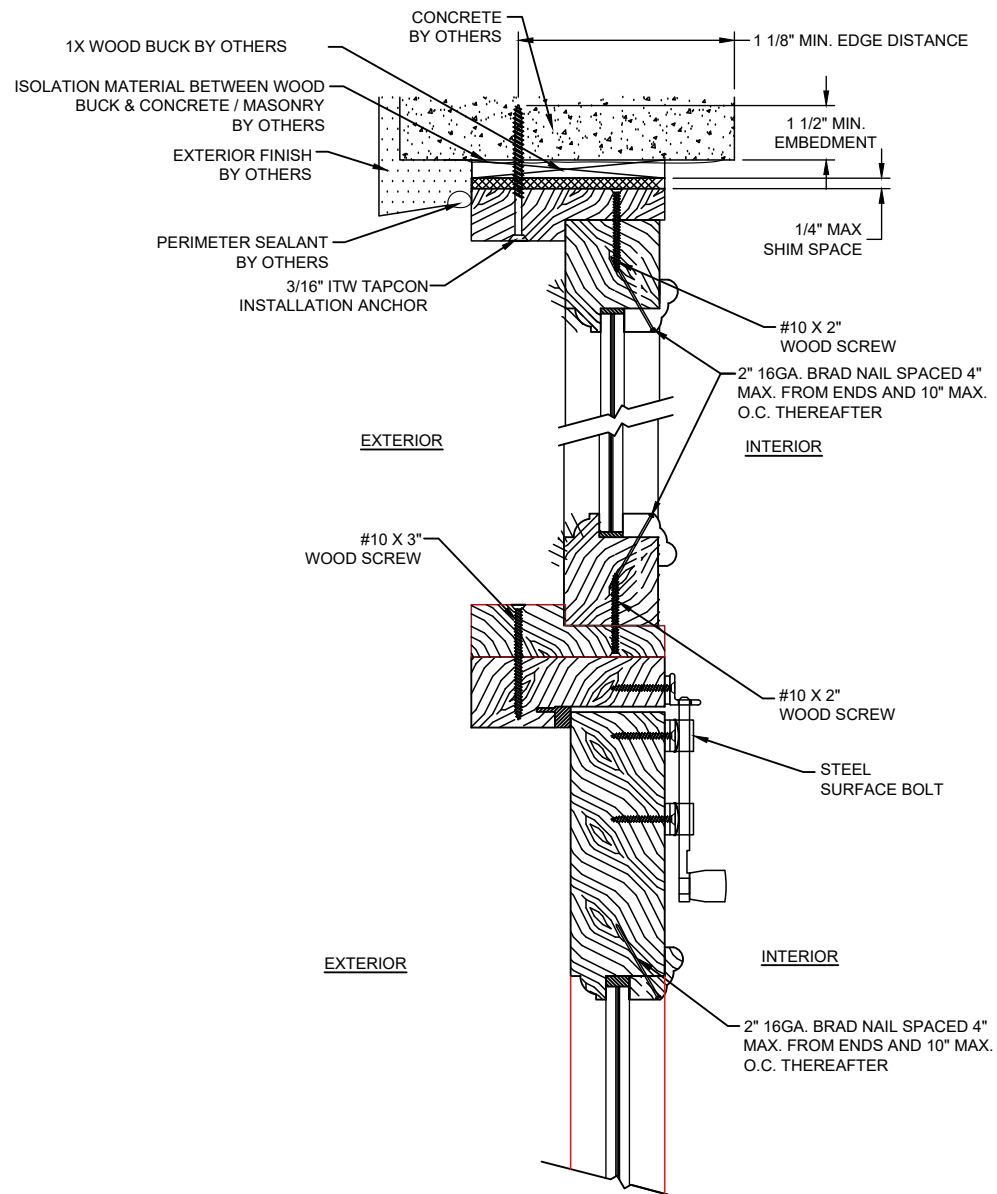

**A VERTICAL SECTION**  
CONCRETE / MASONRY SUBSTRATE

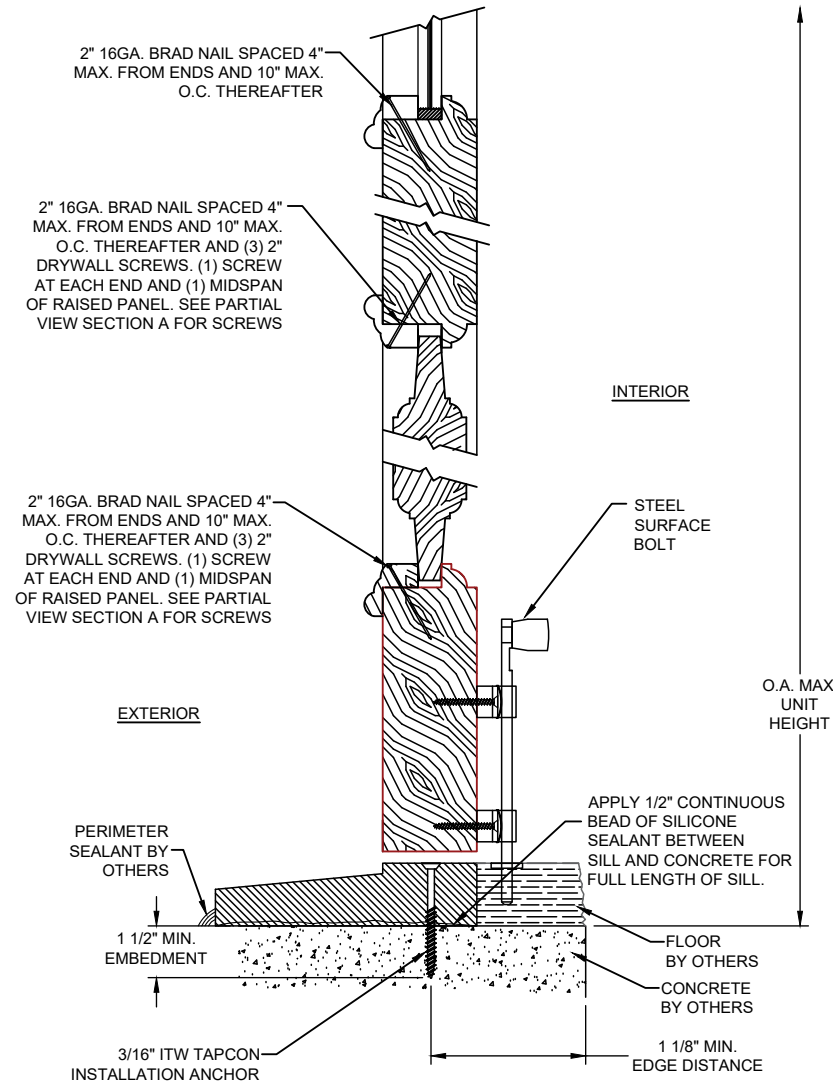

**B VERTICAL SECTION**  
WOOD FRAME SUBSTRATE

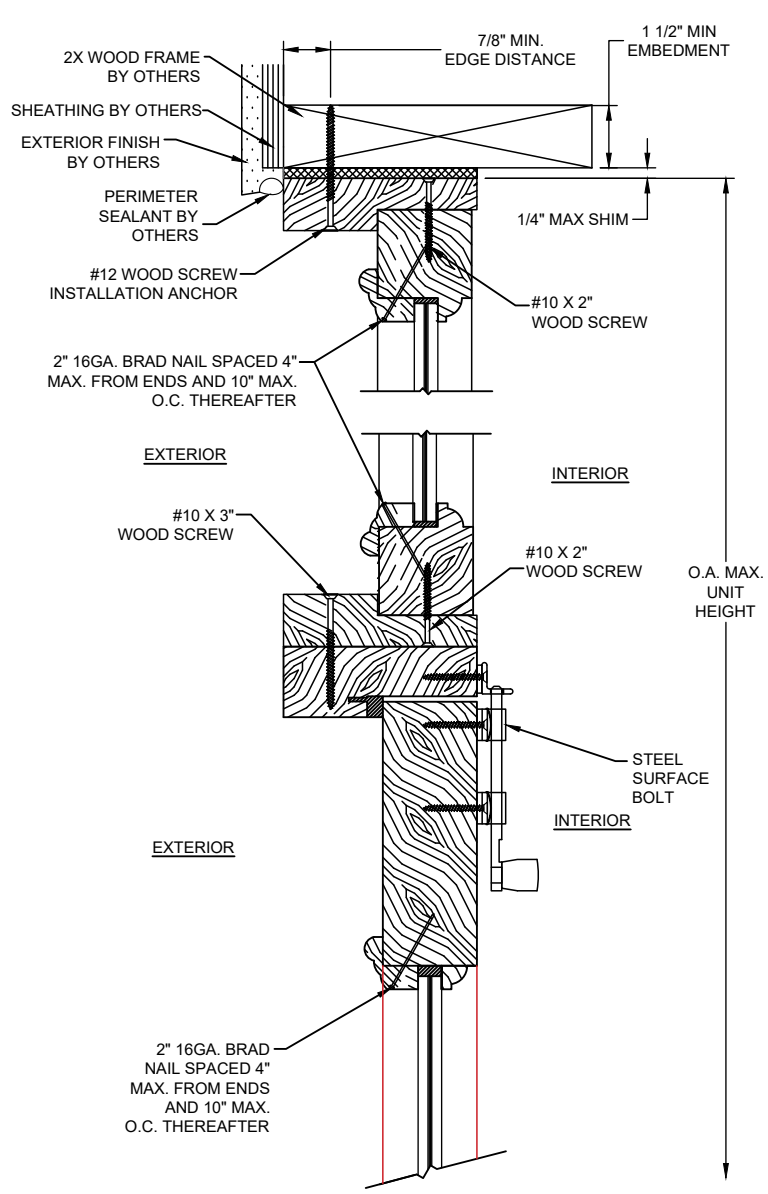

**A VERTICAL SECTION**  
CONCRETE / MASONRY SUBSTRATE

<b>PROJECT #422-0604</b>		RJA	6/12/23	RJA	BY
E	UPDATE TO 8TH EDITION (2023) FBC	D	UPDATE TO 7TH EDITION (2020) FBC	REV	DATE
<b>NEW ERRA DOORS CORP, dba CUSTOM DOOR &amp; MILLWORK</b> 2787 N. AIRPORT RD., UNIT NO. 410 FORT MYERS, FLORIDA 33907		DATE:	09/25/08	DRAWING NO.:	CDM0003
TITLE: IMPACT DOUBLE GLAZED DOORS W/TRANSOM, O/S & I/S INSWING INSTALLATION - VERTICAL SECTIONS		DRAWN BY:	BB	SCALE:	N.T.S.
PREPARED BY:		REV:	E	SHEET:	5 OF 7
PTC-PRODUCT DESIGN GROUP, LLC PO BOX 520775 LONGWOOD, FLORIDA 32752 Phone: 321.690.1788 Fax: 321.690.1789 Email: info@ptc-corp.com					

Robert J. Amoruso, P.E.  
FL P.E. No. 49752

# OUTSWING INSTALLATION HORIZONTAL SECTION VIEWS

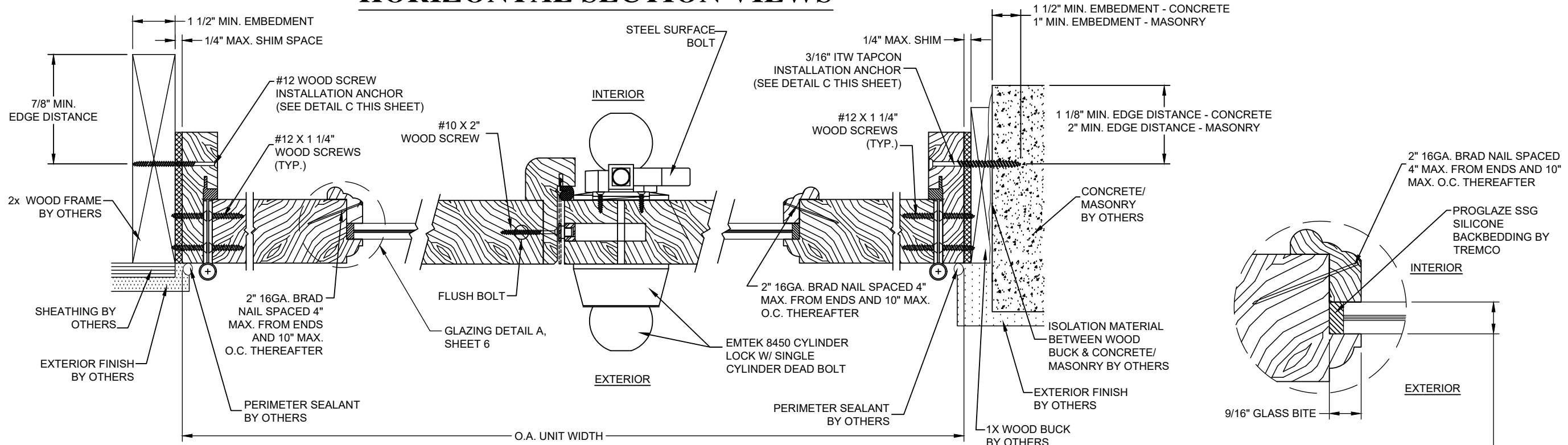

**C HORIZONTAL SECTION**  
WOOD FRAME SUBSTRATE

**E HORIZONTAL SECTION**  
ASTRAGAL

**D HORIZONTAL SECTION**  
CONCRETE / MASONRY SUBSTRATE

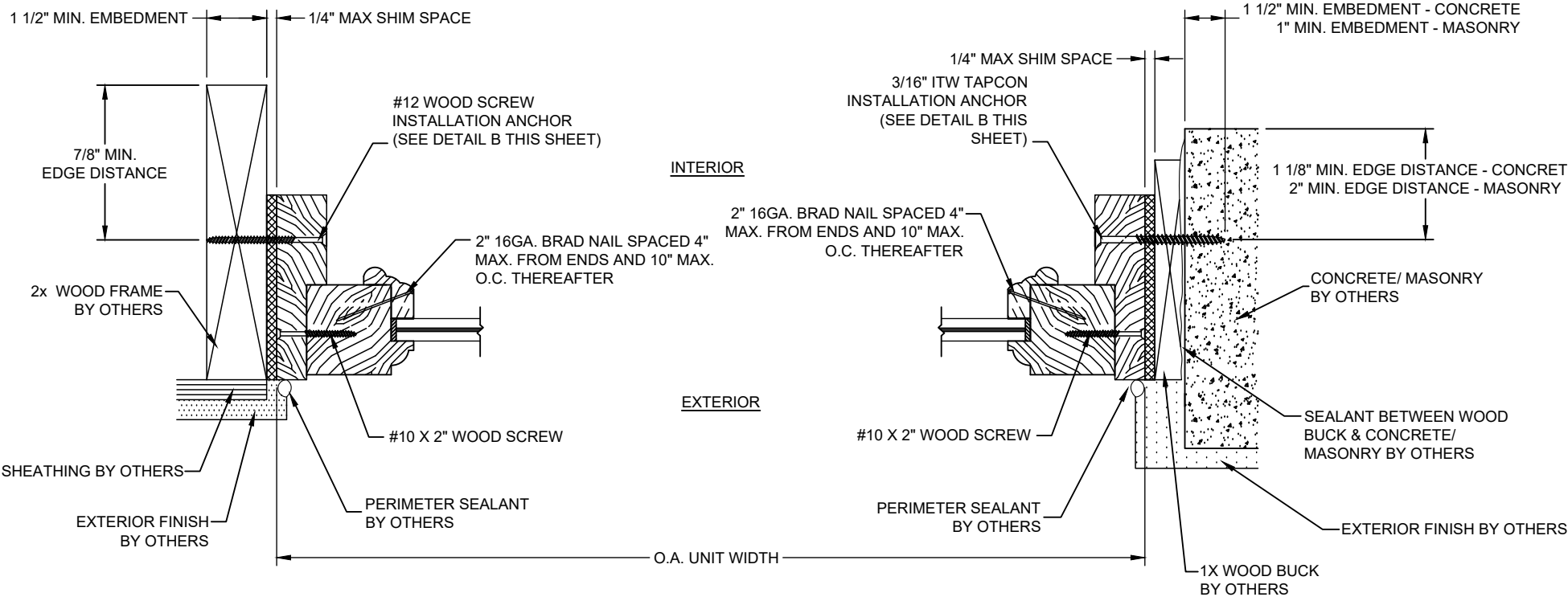

**F HORIZONTAL SECTION**  
WOOD FRAME SUBSTRATE

**G HORIZONTAL SECTION**  
CONCRETE / MASONRY SUBSTRATE

## GLAZING DETAIL A

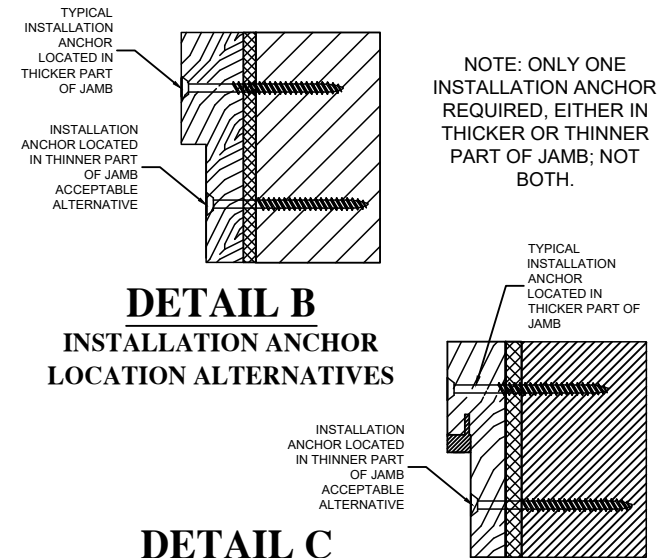

PROJECT #422-0604

NEW ERRA DOORS CORP, dba CUSTOM DOOR & MILLWORK  
2787 N. AIRPORT RD., UNIT NO. 410  
FORT MYERS, FLORIDA 33907

TITLE: IMPACT DOUBLE GLAZED DOORS W/TRANSOM, OIS & I/S  
OUTSWING INSTALLATION - HORIZONTAL SECTIONS / GLAZING DETAIL

DATE:	09/25/08
DRAWING NO.:	CDM0003
SCALE:	N.T.S.
REV.:	6 OF 7
DRAWN BY:	BB
PREPARED BY:	E
DATE:	01/24/21
DESCRIPTION:	
BY:	RJA
DATE:	6/12/23
DESCRIPTION:	UPDATE TO 8TH EDITION (2023) FBC
BY:	RJA
DATE:	01/24/21
DESCRIPTION:	UPDATE TO 7TH EDITION (2020) FBC
BY:	
DATE:	
DESCRIPTION:	

Robert J. Amoruso, P.E.  
FL P.E. No. 49752

# INSWING INSTALLATION HORIZONTAL SECTION VIEWS

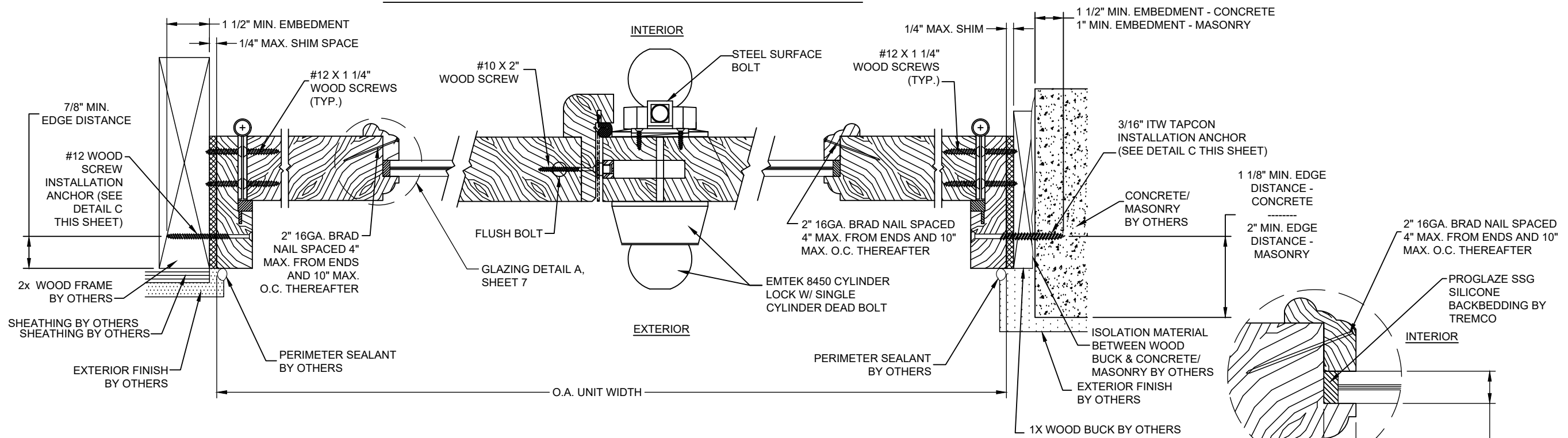

**C HORIZONTAL SECTION**  
WOOD FRAME SUBSTRATE

**E HORIZONTAL SECTION**  
ASTRAGAL

**D HORIZONTAL SECTION**  
CONCRETE / MASONRY SUBSTRATE

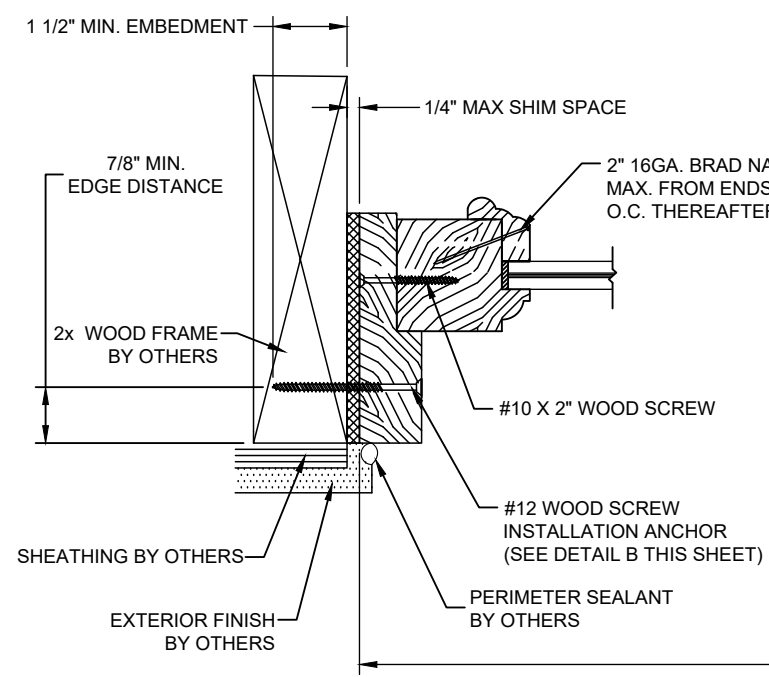

**F HORIZONTAL SECTION**  
WOOD FRAME SUBSTRATE

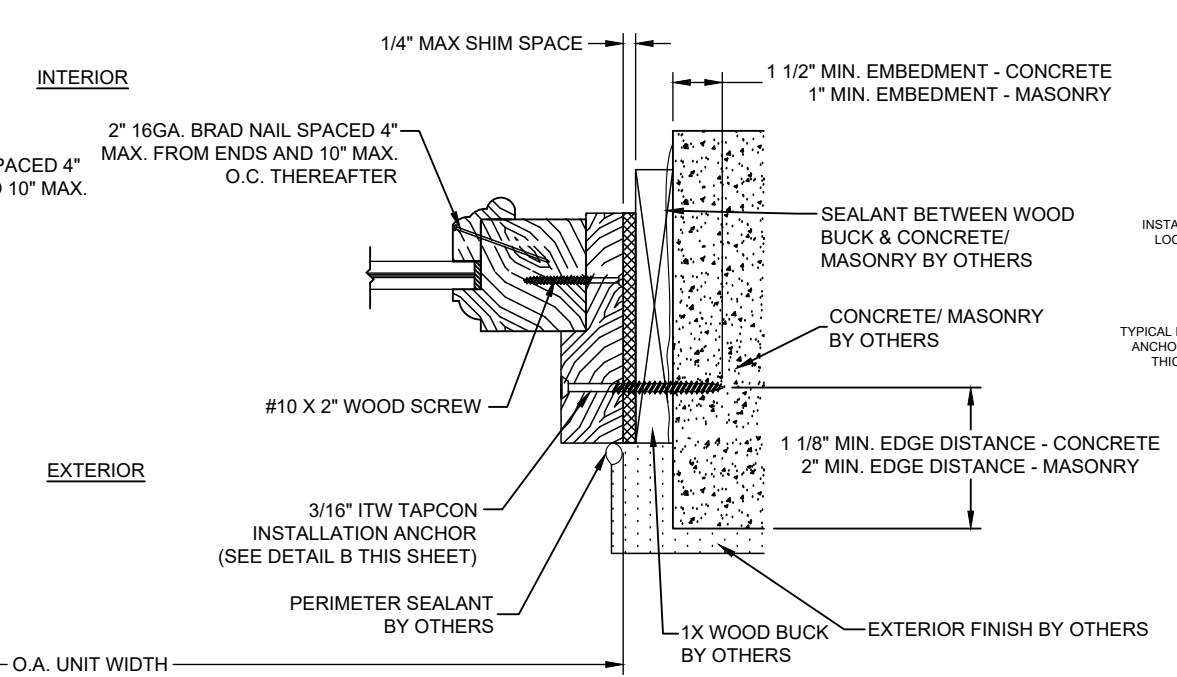

**G HORIZONTAL SECTION**  
CONCRETE / MASONRY SUBSTRATE

9/16" O.A. LAMINATED GLASS CONSISTING OF:  
1/4" TEMPERED GLASS, 0.100" PVB  
LAMINATE BY UVEKOL, 1/4" HEAT STRENGTHENED GLASS

### GLAZING DETAIL A

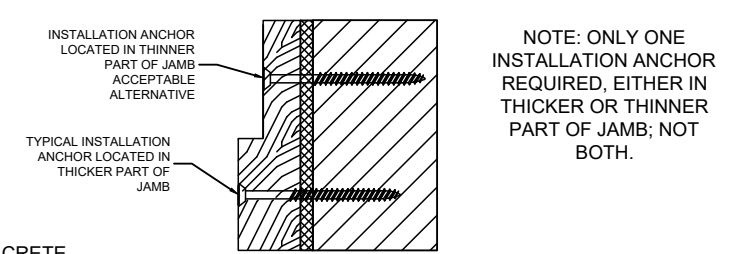

NOTE: ONLY ONE INSTALLATION ANCHOR REQUIRED, EITHER IN THICKER OR THINNER PART OF JAMB; NOT BOTH.

### DETAIL C

#### INSTALLATION ANCHOR LOCATION ALTERNATIVES

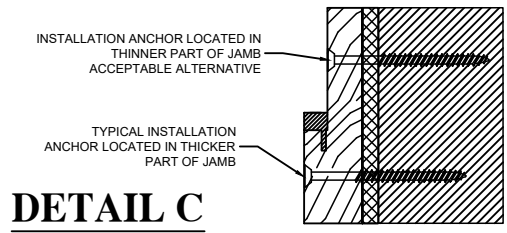

PROJECT #422-0604		DATE	BY
		6/12/23	RJA
DESCRIPTION	REVISION	DATE	BY
UPDATE TO 8TH EDITION (2023) FBC	E	01/24/21	RJA
UPDATE TO 7TH EDITION (2020) FBC	D		

NEW ERRA DOORS CORP, dba CUSTOM DOOR & MILLWORK 2787 N. AIRPORT RD., UNIT NO. 410 FORT MYERS, FLORIDA 33907		DRAWN BY:	DATE:
TITLE: IMPACT DOUBLE GLAZED DOORS W/TRANSOM, O/S & I/S INSWING INSTALLATION - HORIZONTAL SECTIONS / GLAZING DETAIL		BB	09/25/08
PREPARED BY:		SCALE:	DRAWING NO.:
P.T.C. PRODUCT DESIGN GROUP, LLC PO BOX 520775 LONGWOOD, FLORIDA 32752 FBPECA, NO. 25835		N.T.S.	CDM0003
		REV:	SHEET:
		E	7 OF 7

Robert J. Amoroso, P.E.  
FL P.E. No. 49752



MIAMI-DADE COUNTY  
**PRODUCT CONTROL SECTION**  
 11805 SW 26 Street, Room 208  
 Miami, Florida 33175-2474  
 T (786) 315-2590 F (786) 315-2599  
[www.miamidade.gov/building](http://www.miamidade.gov/building)

DEPARTMENT OF REGULATORY AND ECONOMIC RESOURCES (RER)  
 BOARD AND CODE ADMINISTRATION DIVISION  
**NOTICE OF ACCEPTANCE (NOA)**

**Unique Custom Doors, LLC**  
**2787 N. Airport Road Unit 411**  
**Ft. Myers, FL 33907**

**SCOPE:**

This NOA is being issued under the applicable rules and regulations governing the use of construction materials. The documentation submitted has been reviewed and accepted by Miami-Dade County RER-Product Control Section to be used in Miami-Dade County and other areas where allowed by the Authority Having Jurisdiction (AHJ).

This NOA shall not be valid after the expiration date stated below. The Miami-Dade County Product Control Section (In Miami-Dade County) and/ or the AHJ (in areas other than Miami-Dade County) reserve the right to have this product or material tested for quality assurance purposes. If this product or material fails to perform in the accepted manner, the manufacturer will incur the expense of such testing and the AHJ may immediately revoke, modify, or suspend the use of such product or material within their jurisdiction. RER reserves the right to revoke this acceptance if it is determined by Miami-Dade County Product Control Section that this product or material fails to meet the requirements of the applicable building code.

This product is approved as described herein and has been designed to comply with the Florida Building Code, including the High Velocity Hurricane Zone.

**DESCRIPTION: Series “Sidelite/Transom” Wood Fixed Window - L.M.I.**

**APPROVAL DOCUMENT:** Drawing No. **UCD002**, titled “Unique Custom Doors – Sidelite & Transom”, sheets 1 through 7 of 7, dated 04/11/24, prepared by Building Drops, Inc., signed and sealed by Hermes F. Norero, P.E., bearing the Miami-Dade County Product Control Approval stamp with the Notice of Acceptance number and approval date by the Miami-Dade County Product Control Section.

**MISSILE IMPACT RATING: Large and Small Missile Impact Resistant**

**LABELING:** Each unit shall bear a permanent label with the manufacturer's name or logo, city, state, model/series, and following statement: "Miami-Dade County Product Control Approved", unless otherwise noted herein.

**RENEWAL** of this NOA shall be considered after a renewal application has been filed and there has been no change in the applicable building code negatively affecting the performance of this product.

**TERMINATION** of this NOA will occur after the expiration date or if there has been a revision or change in the materials, use, and/ or manufacture of the product or process. Misuse of this NOA as an endorsement of any product, for sales, advertising or any other purposes shall automatically terminate this NOA. Failure to comply with any section of this NOA shall be cause for termination and removal of NOA.

**ADVERTISEMENT:** The NOA number preceded by the words Miami-Dade County, Florida, and followed by the expiration date may be displayed in advertising literature. If any portion of the NOA is displayed, then it shall be done in its entirety.

**INSPECTION:** A copy of this entire NOA shall be provided to the user by the manufacturer or its distributors and shall be available for inspection at the job site at the request of the Building Official.

This NOA consists of this page 1 and evidence pages E-1 and E-2, as well as approval document mentioned above.

The submitted documentation was reviewed by **Manuel Perez, P.E.**

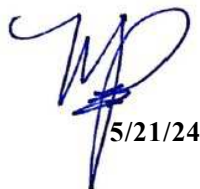

  
 5/21/24

**NOA No. 24-0423.01**  
**Expiration Date: May 30, 2029**  
**Approval Date: May 30, 2024**  
 Page 1



Unique Custom Doors, LLC

NOTICE OF ACCEPTANCE: EVIDENCE SUBMITTED

**A. DRAWINGS**

1. Manufacturer's die drawings and sections.  
*(Submitted under NOA No. 24-0423.01)*
2. Drawing No **UCD002**, titled “Unique Custom Doors – Sidelite & Transom”, sheets 1 through 7 of 7, dated 04/11/24, prepared by Building Drops, Inc., signed and sealed by Hermes F. Norero, P.E.

**B. TESTS**

1. Test reports on: 1) Air Infiltration Test, per FBC, TAS 202-94  
2) Uniform Static Air Pressure Test, Loading per FBC, TAS 202-94  
3) Water Resistance Test, per FBC, TAS 202-94  
4) Forced Entry Test, per ASTM F558 and TAS 202-94  
5) Large Missile Impact Test per FBC, TAS 201-94  
6) Cyclic Wind Pressure Loading per FBC, TAS 203-94  
along with marked-up drawings and installation diagram of a wood sidelite, direct, set fixed window, prepared by QAI Laboratories, Test Report No. **MED-1064a**, dated 04/08/24, signed and sealed by Idalmis Ortega, P.E.
2. Test reports on: 1) Air Infiltration Test, per FBC, TAS 202-94  
2) Uniform Static Air Pressure Test, Loading per FBC, TAS 202-94  
3) Water Resistance Test, per FBC, TAS 202-94  
4) Large Missile Impact Test per FBC, TAS 201-94  
5) Cyclic Wind Pressure Loading per FBC, TAS 203-94  
along with marked-up drawings and installation diagram of a wood sidelite, direct, set fixed window, prepared by QAI Laboratories, Test Report No. **MED-2015a**, dated 03/27/24, signed and sealed by Idalmis Ortega, P.E.
3. Test reports on: 1) Uniform Static Air Pressure Test, Loading per FBC, TAS 202-94  
2) Large Missile Impact Test per FBC, TAS 201-94  
3) Cyclic Wind Pressure Loading per FBC, TAS 203-94  
along with marked-up drawings and installation diagram of a wood radius transom and elliptical transom, direct, set fixed window, prepared by QAI Laboratories, Test Report No. **MED-2015b**, dated 03/27/24, signed and sealed by Idalmis Ortega, P.E.

**C. CALCULATIONS**

1. Anchor verification calculations and structural analysis, complying with **FBC 8<sup>th</sup> Edition (2023)**, dated 04/11/24 and 05/07/24, prepared by Building Drops, Inc. signed and sealed by Hermes F. Norero, P.E.
2. Glazing complies with **ASTM E1300-16**

  
Manuel Perez, P.E.  
Product Control Examiner  
NOA No. 24-0423.01  
Expiration Date: May 30, 2029  
Approval Date: May 30, 2024

**Unique Custom Doors, LLC**

**NOTICE OF ACCEPTANCE: EVIDENCE SUBMITTED**

**D. QUALITY ASSURANCE**

1. Miami-Dade Department of Regulatory and Economic Resources (RER)

**E. MATERIAL CERTIFICATIONS**

1. Notice of Acceptance No. **23-0717.30** issued to **Kuraray America, Inc.** for their “**SentryGlas® (Clear and White) Glass Interlayers**” dated 08/31/23, expiring on 07/04/28.

**F. STATEMENTS**

1. Statement letter of conformance, complying with **FBC 8<sup>th</sup> Edition (2023)** and of no financial interest, dated April 11, 2024, issued by Building Drops, Inc. signed and sealed by Hermes F. Norero, P.E.

**G. OTHERS**

1. None.

  
Manuel Pérez, P.E.  
Product Control Examiner  
NOA No. 24-0423.01  
Expiration Date: May 30, 2029  
Approval Date: May 30, 2024

4/15/2024 6:12 PM

s:\projects\new erra doors\md-23-1236.1 - miami dade submittal - impact sidelite and transom.dwg\ucd002.dwg

# UNIQUE CUSTOM DOORS

## SIDELITE & TRANSOM

**UNIQUE**  
CUSTOM DOORS

2787 N AIRPORT ROAD #411  
FORT MYERS, FL 33907  
PH: (239) 340-1229

**GENERAL NOTES:**

- THE PRODUCT SHOWN HEREIN IS DESIGNED AND MANUFACTURED TO COMPLY WITH THE 8TH EDITION (2023) FLORIDA BUILDING CODE (FBC) INCLUDING HVHZ. ALL PRODUCTS UNDER THE SCOPE OF THIS DOCUMENT HAVE BEEN EVALUATED ACCORDING TO THE FOLLOWING:
  - AAMA/WDMA/CSA 101/I.S.2/A440-17
  - ASTM E1886-19
  - ASTM E1996-17
  - TAS 201-94
  - TAS 202-94
  - TAS 203-94
- ADEQUACY OF THE EXISTING STRUCTURAL CONCRETE/MASONRY, 2X AND METAL STUD FRAMING AS A MAIN WIND FORCE RESISTING SYSTEM CAPABLE OF WITHSTANDING AND TRANSFERRING APPLIED PRODUCT LOADS TO THE FOUNDATION IS THE RESPONSIBILITY OF THE ENGINEER OR ARCHITECT OF RECORD FOR THE PROJECT OF INSTALLATION.
- 1X AND 2X BUCKS (WHEN USED) SHALL BE DESIGNED AND ANCHORED TO PROPERLY TRANSFER ALL LOADS TO THE STRUCTURE. BUCK DESIGN AND INSTALLATION IS THE RESPONSIBILITY OF THE ENGINEER OR ARCHITECT OF RECORD FOR THE PROJECT OF INSTALLATION.
- INSTALL INDIVIDUAL INSTALLATION ANCHORS WITHIN A TOLERANCE OF ±1/4 INCH OF THE DEPICTED LOCATION IN THE ANCHOR LAYOUT DETAIL (I.E., WITHOUT CONSIDERATION OF TOLERANCES). TOLERANCES ARE NOT CUMULATIVE FROM ONE INSTALLATION ANCHOR TO THE NEXT.
- THE INSTALLATION DETAILS DESCRIBED HEREIN ARE GENERIC AND MAY NOT REFLECT ACTUAL CONDITIONS FOR A SPECIFIC SITE. IF SITE CONDITIONS CAUSE INSTALLATION TO DEVIATE FROM THE REQUIREMENTS DETAILED HEREIN, A LICENSED ENGINEER OR ARCHITECT SHALL PREPARE SITE SPECIFIC DOCUMENTS FOR USE WITH THIS DOCUMENT.
- APPROVED IMPACT PROTECTIVE SYSTEM **IS NOT REQUIRED** TO PROTECT THIS PRODUCT IN AREAS REQUIRING IMPACT RESISTANCE.
- FRAME MATERIAL: MAHOGANY.
- GLASS MEETS THE REQUIREMENTS OF ASTM E 1300 GLASS CHARTS. SEE SHEET 1 FOR GLAZING DETAILS.

TABLE OF CONTENTS	
SHEET	SHEET DESCRIPTION
1	GENERAL NOTES AND GLAZING DETAILS
2	TYPICAL ELEVATIONS
3	ANCHOR LAYOUTS
4	VERTICAL SECTIONS
5	HORIZONTAL SECTIONS
6	INSTALLATION DETAILS AND NOTES
7	BILL OF MATERIALS AND COMPONENTS

DESIGN PRESSURE RATING				
GLASS TYPE	CONFIGURATION	MAX. SIZE	DESIGN PRESSURE	MISSILE RATING
G1	RECTANGLE TRANSOM/SIDELITE, TRIANGLE/RADIUS/ELLIPTICAL TRANSOM	SEE SHEET 2	+/- 75 PSF	LARGE & SMALL MISSILE IMPACT
G2	RECTANGLE TRANSOM/SIDELITE	44.25" X 123.125"	+/- 60 PSF	
G2	TRIANGLE/RADIUS/ELLIPTICAL TRANSOM	99.125" X 50.25"	+/- 75 PSF	

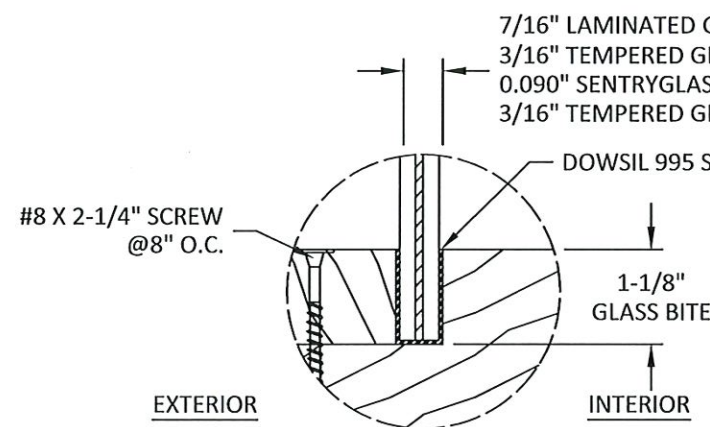

**GLAZING TYPE G1**

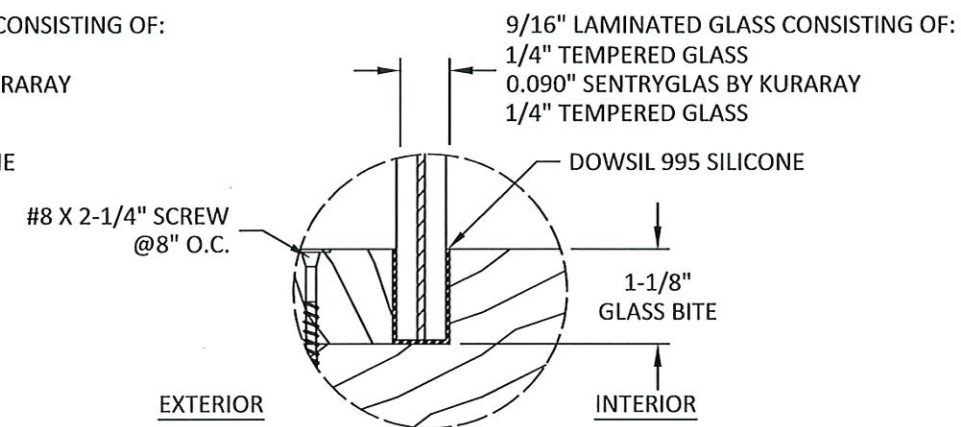

**GLAZING TYPE G2**

- GLAZING NOTES:**
- GLASS TYPE & THICKNESS COMPLIES WITH ASTM E1300 REQUIREMENTS. TEMPER AND SAFETY GLAZING REQUIREMENTS SHALL BE REVIEWED ON A SITE SPECIFIC BASIS.
  - SETTING BLOCK DUROMETER HARDNESS OF 70-90 (SHORE A) AS REFERENCED IN FBC CHAPTER 24.
  - SETTING BLOCKS TO BE LOCATED AT 1/4 SPAN LENGTH FOR GLASS WIDER THAN 36" AS PER FBC CHAPTER 24.
  - D.L.O. AND DESIGN PRESSURES MAY NOT EXCEED MAX VALUES IN SHEETS 1 & 2.

**PRODUCT APPROVED**  
As complying with the Florida Building Code  
NOA-No. **24-0423.01**  
Approval Date: **05/30/2024**  
By: *Manuel Ferraz*  
Miami-Dade Product Control

TITLE: SIDELITE & TRANSOM  
GENERAL NOTES & GLAZING DETAILS

PREPARED BY: BUILDING DROPS, INC.  
1900 NE MIAMI CT., STE. 2-15  
MIAMI, FL 33132  
PH: (954) 395-8478  
FAX: (954) 744-4738  
WEB: www.buildingdrops.com

BD BUILDING DROPS

REMARKS	BY	DATE

THE INSTALLATION DETAILS DESCRIBED HEREIN ARE GENERIC AND MAY NOT REFLECT ACTUAL CONDITIONS FOR A SPECIFIC SITE. IF SITE CONDITIONS CAUSE INSTALLATION TO DEVIATE FROM THE REQUIREMENTS DETAILED HEREIN, A LICENSED ENGINEER OR ARCHITECT SHALL PREPARE SITE SPECIFIC DOCUMENTS FOR USE WITH THIS DOCUMENT.

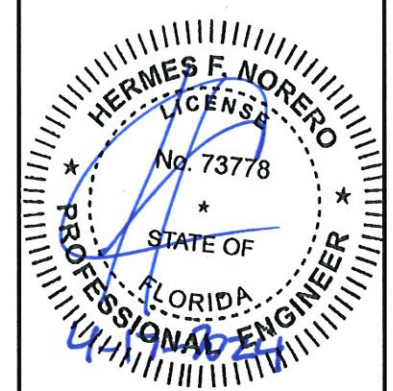

HERMES F. NORERO, P.E.  
FLORIDA P.E. No. 73778  
BUILDING DROPS, INC.  
1900 NE MIAMI CT., STE. 2-15  
MIAMI, FL 33132  
FBPE CERT. OF AUTHORIZATION No. 29578

DATE: **04.11.2024**

DWG. BY: **MS**      CHK. BY: **HFN**

SCALE: **NTS**

DWG. #: **UCD002**

SHEET: **1**

OF 7

4/15/2024 6:13 PM

s:\projects\new erra doors\md-23-1236.1 - miami daide submittal - impact sidelite and transom.dwg\lucf002.dwg

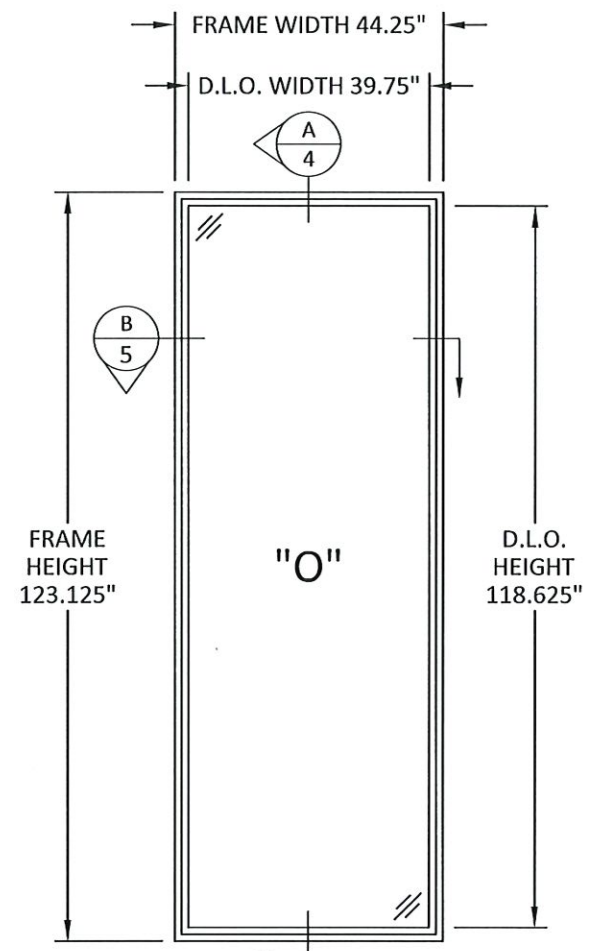

**TYPICAL ELEVATION**  
RECTANGLE SIDELITE/TRANSOM

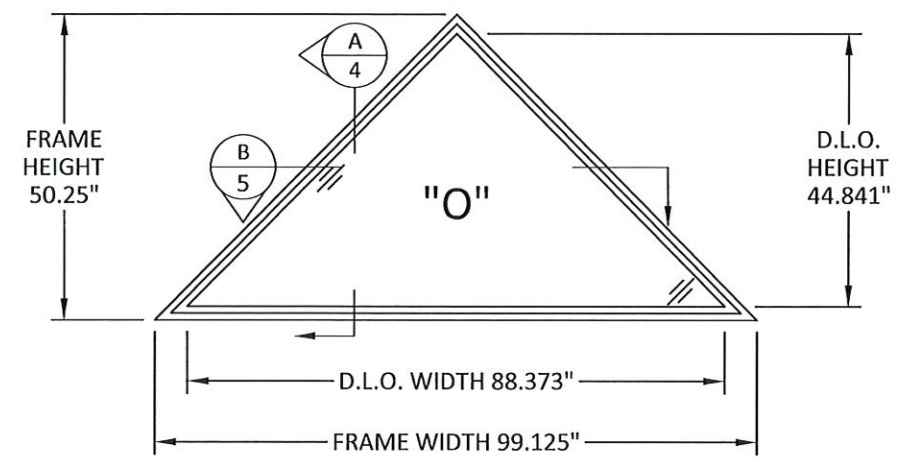

**TYPICAL ELEVATION**  
TRIANGLE TRANSOM

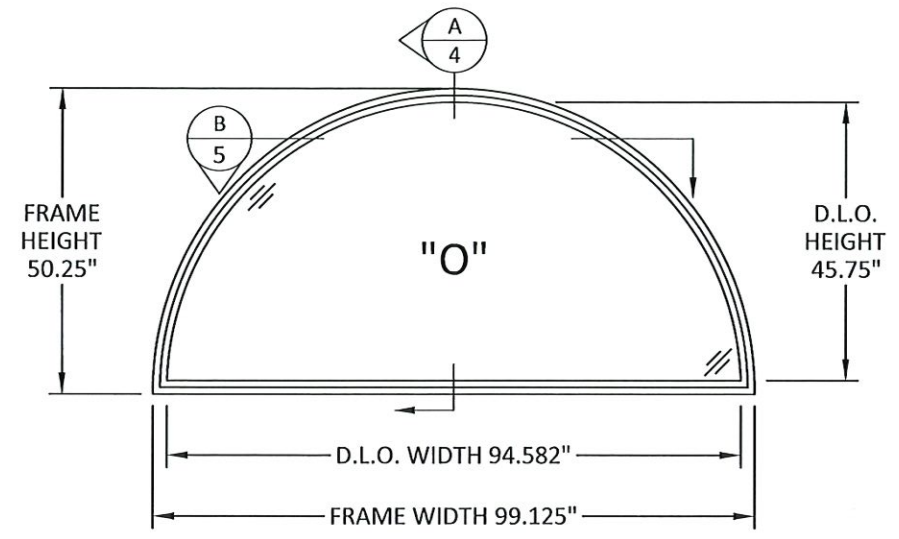

**TYPICAL ELEVATION**  
RADIUS TRANSOM

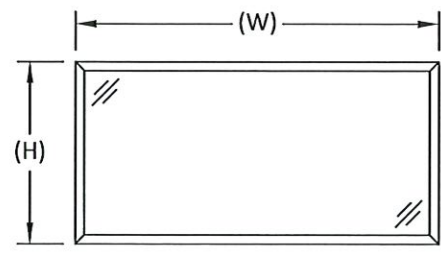
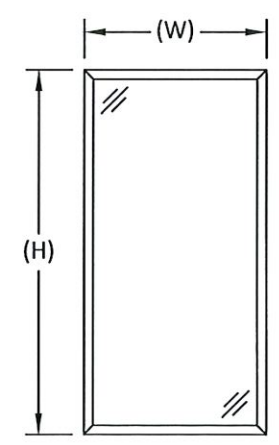

NOTES:  
FRAME WIDTH (W) AND HEIGHT (H) ARE INTERCHANGEABLE FOR ALL SIZES SHOWN HEREIN NOT TO EXCEED MAXIMUM TESTED SQUARE FOOT AREA. ANCHOR SPACING SHALL NOT EXCEED THOSE SHOWN ON SHEET 3 FOR LONG OR SHORT LEG OF UNIT.

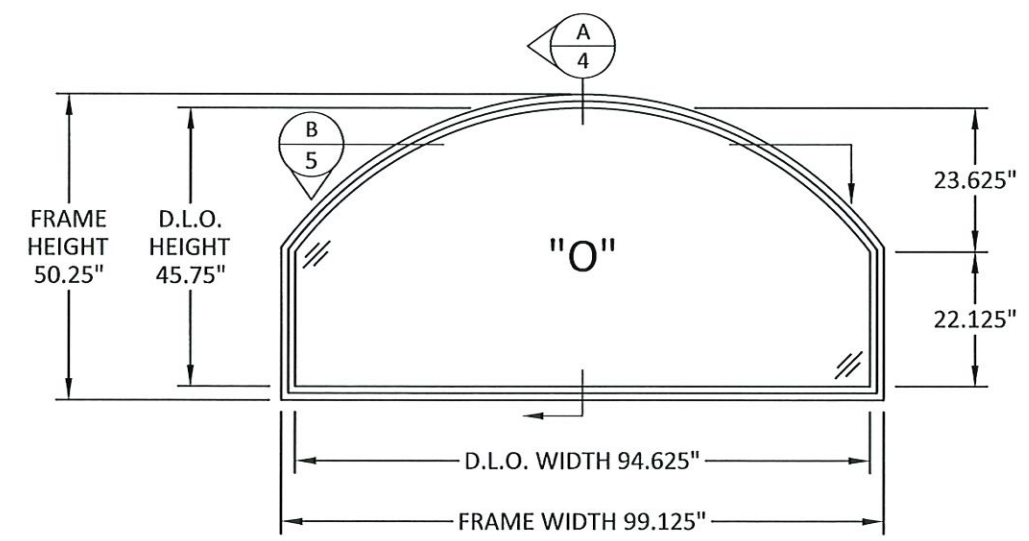

**TYPICAL ELEVATION**  
ELLIPTICAL TRANSOM

**PRODUCT APPROVED**  
As complying with the Florida Building Code  
NOA-No. **24-0423.01**  
Approval Date: **05/30/2024**  
By: *Manuel Perez*  
Miami-Dade Product Control



2787 N AIRPORT ROAD #411  
FORT MYERS, FL 33907  
PH: (239) 340-1229

TITLE: SIDELITE & TRANSOM  
TYPICAL ELEVATIONS  
PREPARED BY: BUILDING DROPS, INC.  
1900 NE MIAMI CT., STE. 2-15  
MIAMI, FL 33132  
PH: (954) 399-8478  
FAX: (954) 744-4738  
WEB: www.buildingdrops.com

REMARKS	BY	DATE

THE INSTALLATION DETAILS DESCRIBED HEREIN ARE GENERIC AND MAY NOT REFLECT ACTUAL CONDITIONS FOR A SPECIFIC SITE. IF SITE CONDITIONS CAUSE INSTALLATION TO DEVIATE FROM THE REQUIREMENTS DETAILED HEREIN, A LICENSED ENGINEER OR ARCHITECT SHALL PREPARE SITE SPECIFIC DOCUMENTS FOR USE WITH THIS DOCUMENT.

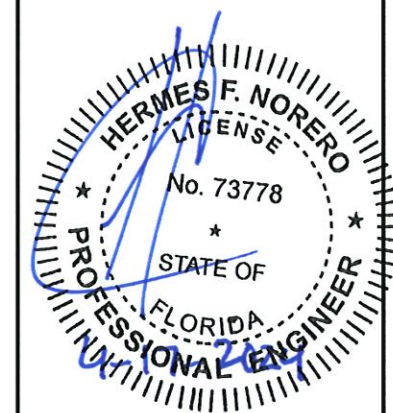

HERMES F. NORERO, P.E.  
FLORIDA P.E. No. 73778  
BUILDING DROPS, INC.  
1900 NE MIAMI CT., STE. 2-15  
MIAMI, FL 33132  
FBPE CERT. OF AUTHORIZATION No. 29578

DATE:	04.11.2024	
DWG. BY:	MS	CHK. BY: HFN
SCALE:	NTS	
DWG. #:	UCD002	
SHEET:	2	

4/15/2024 6:13 PM

s:\projects\new erra doors\md-23-1236.1 - miami dade submittal - impact sidelite and transom.dwg\ucfd002.dwg



2787 N AIRPORT ROAD #411  
FORT MYERS, FL 33907  
PH: (239) 340-1229

TITLE: SIDELITE & TRANSOM  
ANCHOR LAYOUTS  
PREPARED BY: BUILDING DROPS, INC.  
1900 NE MIAMI CT., STE. 2-15  
MIAMI, FL 33132  
PH: (954) 399-8478  
FAX: (954) 744-4738  
WEB: www.buildingdrops.com



REMARKS	BY	DATE

THE INSTALLATION DETAILS DESCRIBED HEREIN ARE GENERIC AND MAY NOT REFLECT ACTUAL CONDITIONS FOR A SPECIFIC SITE. IF SITE CONDITIONS CAUSE INSTALLATION TO DEVIATE FROM THE REQUIREMENTS DETAILED HEREIN, A LICENSED ENGINEER OR ARCHITECT SHALL PREPARE SITE SPECIFIC DOCUMENTS FOR USE WITH THIS DOCUMENT.

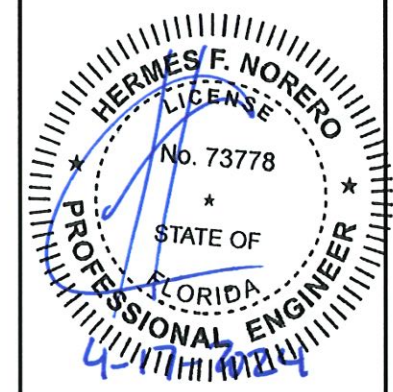

HERMES F. NORERO, P.E.  
FLORIDA P.E. No. 73778  
BUILDING DROPS, INC.  
1900 NE MIAMI CT., STE. 2-15  
MIAMI, FL 33132  
FBPE CERT. OF AUTHORIZATION No. 29578

DATE:	04.11.2024
DWG. BY:	MS
CHK. BY:	HFN
SCALE:	NTS
DWG. #:	UCD002
SHEET:	3

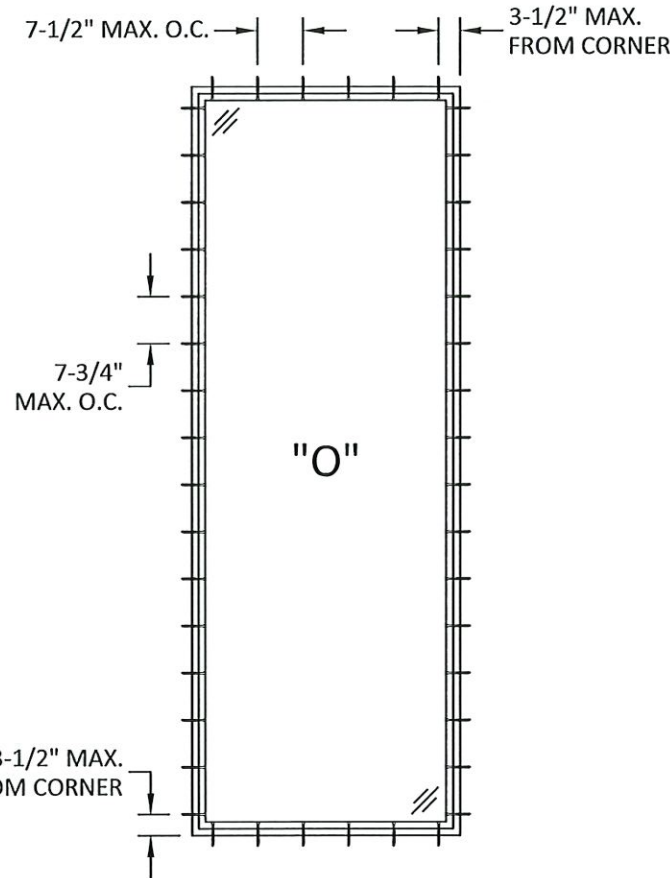

ANCHOR LAYOUT  
RECTANGLE SIDELITE/TRANSOM

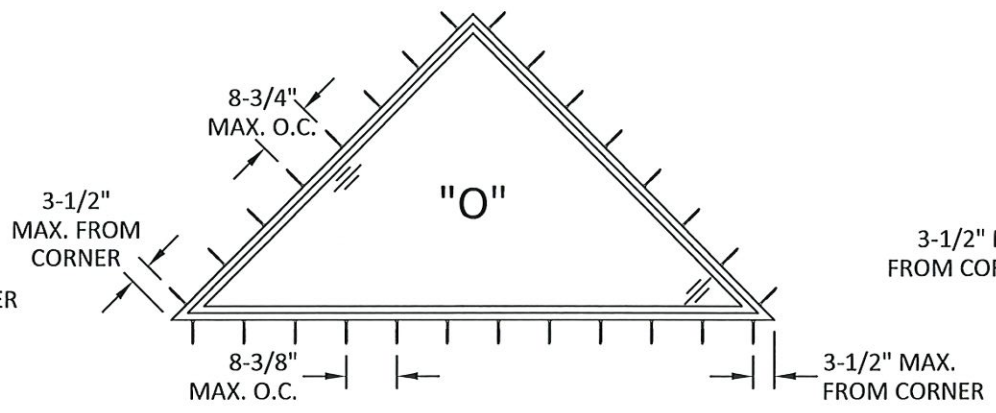

ANCHOR LAYOUT  
TRIANGLE TRANSOM

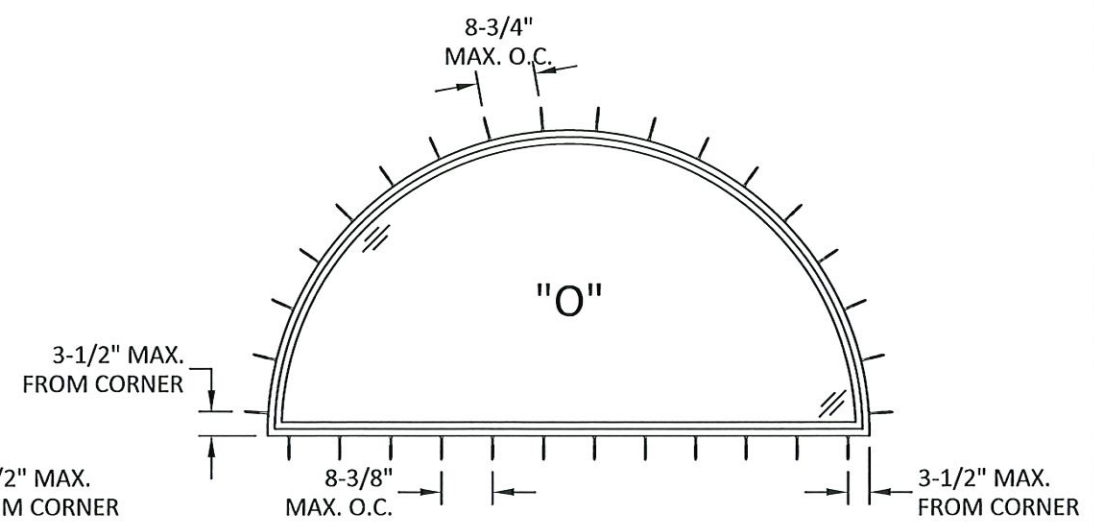

ANCHOR LAYOUT  
RADIUS TRANSOM

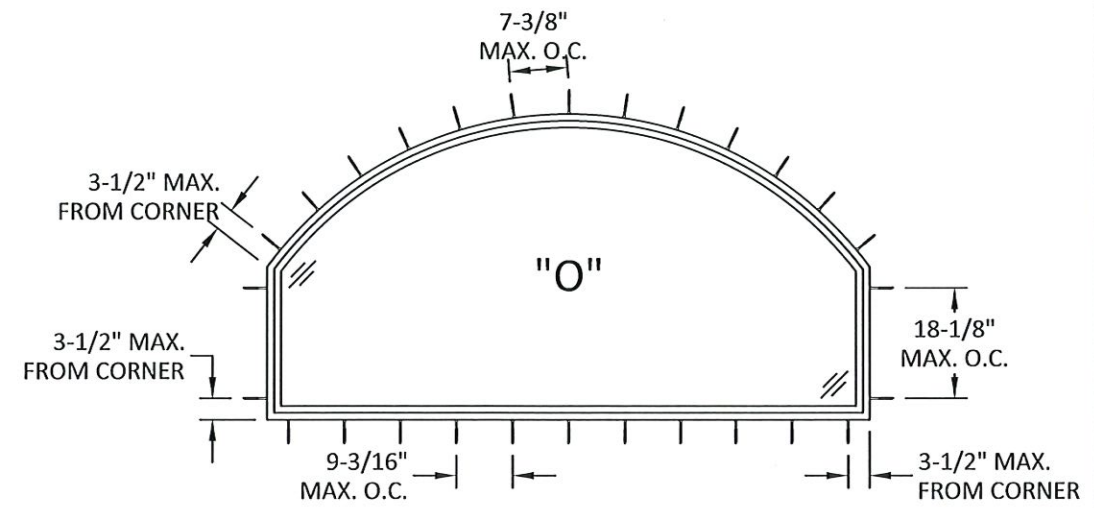

ANCHOR LAYOUT  
ELLIPTICAL TRANSOM

**PRODUCT APPROVED**  
As complying with the Florida  
Building Code  
NOA-No. **24-0423.01**  
Approval Date: **05/30/2024**  
By: *Manuel Ferraz*  
Miami-Dade Product Control

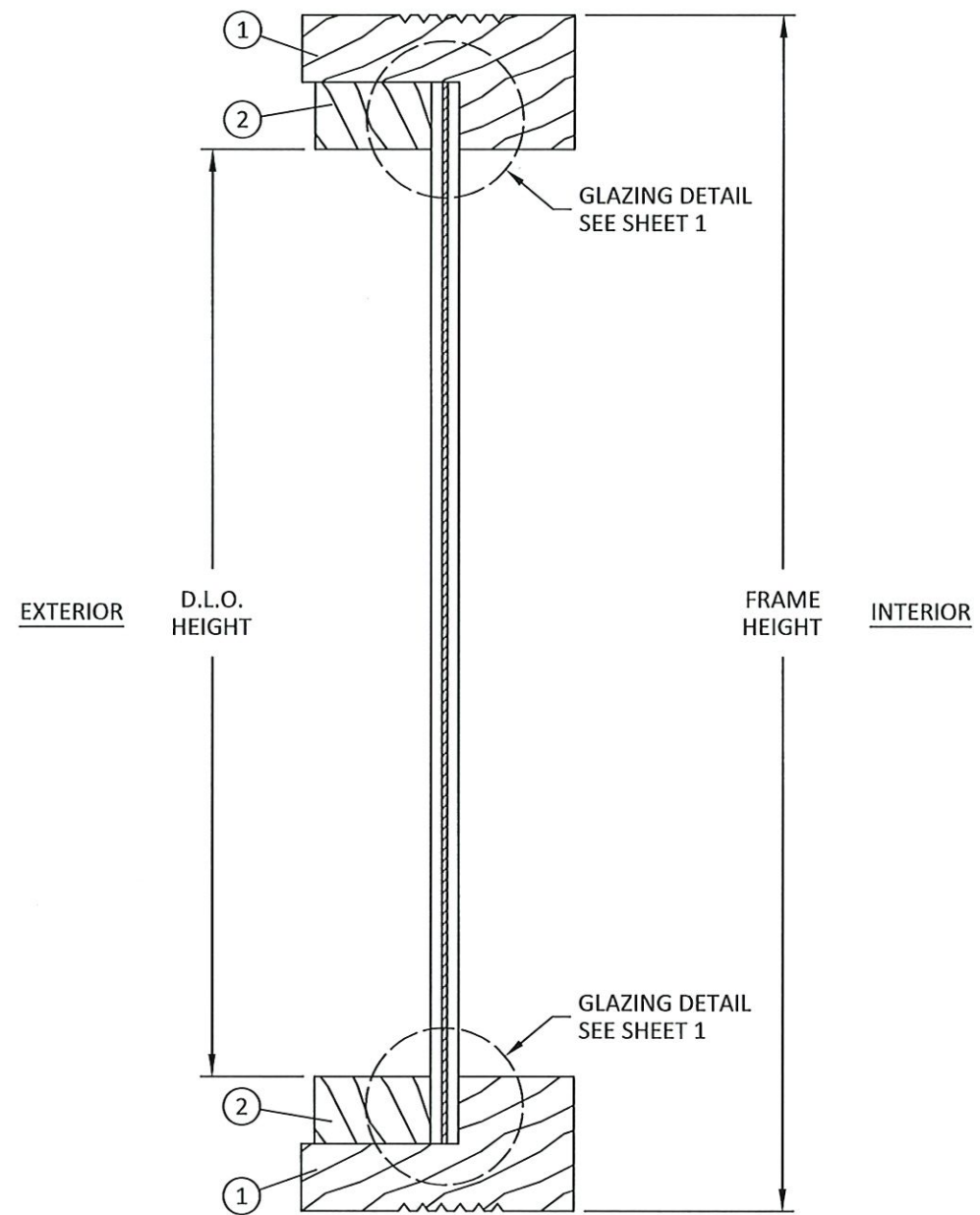

**A**  
**4** VERTICAL SECTION  
SIDELITE/TRANSOM



2787 N AIRPORT ROAD #411  
FORT MYERS, FL 33907  
PH: (239) 340-1229

TITLE: SIDELITE & TRANSOM  
VERTICAL SECTIONS

PREPARED BY: BUILDING DROPS, INC.  
1900 NE MIAMI CT., STE. 2-15  
MIAMI, FL 33132  
PH: (954) 399-8478  
FAX: (954) 744-4738  
WEB: www.buildingdrops.com

**BD**  
BUILDING DROPS

REMARKS	BY	DATE

THE INSTALLATION DETAILS DESCRIBED HEREIN ARE GENERIC AND MAY NOT REFLECT ACTUAL CONDITIONS FOR A SPECIFIC SITE. IF SITE CONDITIONS CAUSE INSTALLATION TO DEVIATE FROM THE REQUIREMENTS DETAILED HEREIN, A LICENSED ENGINEER OR ARCHITECT SHALL PREPARE SITE SPECIFIC DOCUMENTS FOR USE WITH THIS DOCUMENT.

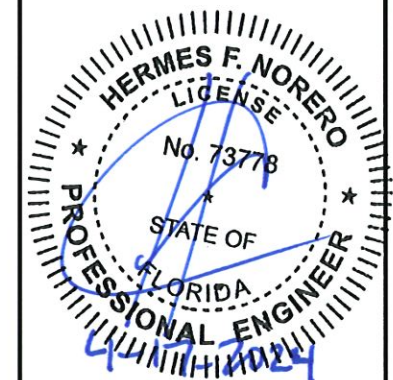

HERMES F. NORERO, P.E.  
FLORIDA P.E. No. 73778  
BUILDING DROPS, INC.  
1900 NE MIAMI CT., STE. 2-15  
MIAMI, FL 33132  
FBPE CERT. OF AUTHORIZATION No. 29578

DATE:	04.11.2024
DWG. BY:	MS
CHK. BY:	HFN
SCALE:	NTS
DWG. #:	UCD002
SHEET:	4

**PRODUCT APPROVED**  
As complying with the Florida Building Code  
NOA-No. **24-0423.01**  
Approval Date: **05/30/2024**  
By: *Manuel Perez*  
Miami-Dade Product Control

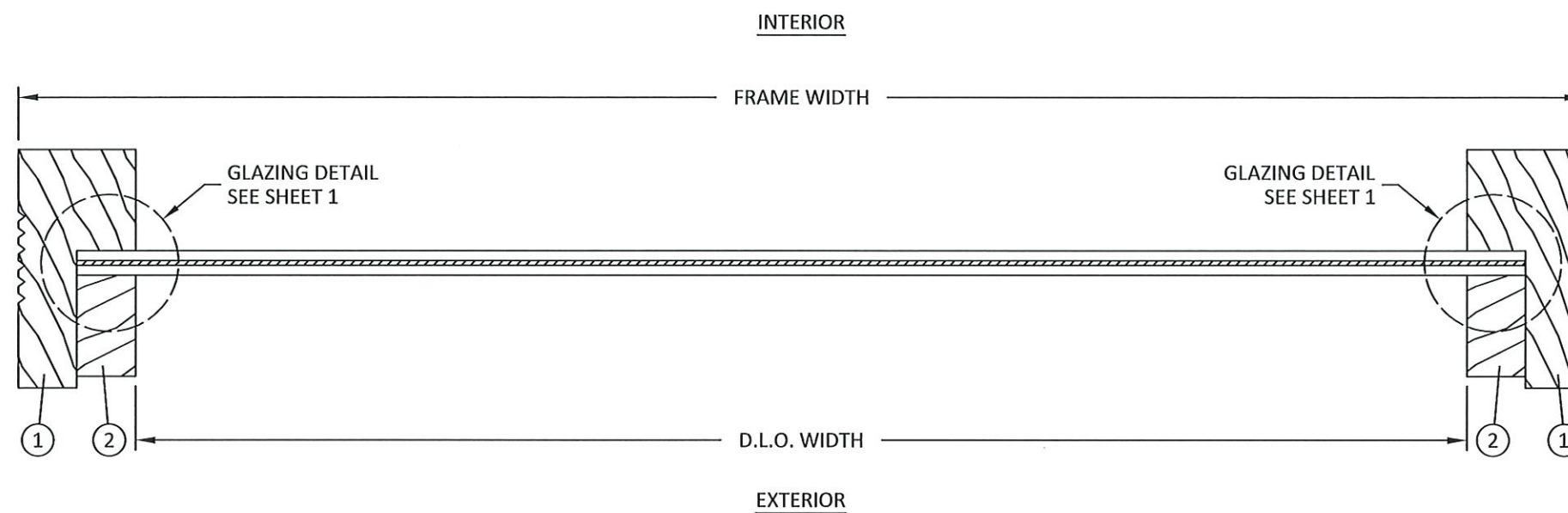

**B**  
**5** HORIZONTAL SECTION  
SIDELITE/TRANSOM

**UNIQUE**  
CUSTOM DOORS

2787 N AIRPORT ROAD #411  
FORT MYERS, FL 33907  
PH: (239) 340-1229

TITLE: SIDELITE & TRANSOM  
HORIZONTAL SECTIONS

PREPARED BY: **BD** BUILDING DROPS

BUILDING DROPS, INC.  
1900 NE MIAMI CT., STE. 2-15  
MIAMI, FL 33132  
PH: (954) 399-8478  
FAX: (954) 744-4738  
WEB: www.buildingdrops.com

REMARKS	BY	DATE

THE INSTALLATION DETAILS DESCRIBED HEREIN ARE GENERIC AND MAY NOT REFLECT ACTUAL CONDITIONS FOR A SPECIFIC SITE. IF SITE CONDITIONS CAUSE INSTALLATION TO DEVIATE FROM THE REQUIREMENTS DETAILED HEREIN, A LICENSED ENGINEER OR ARCHITECT SHALL PREPARE SITE SPECIFIC DOCUMENTS FOR USE WITH THIS DOCUMENT.

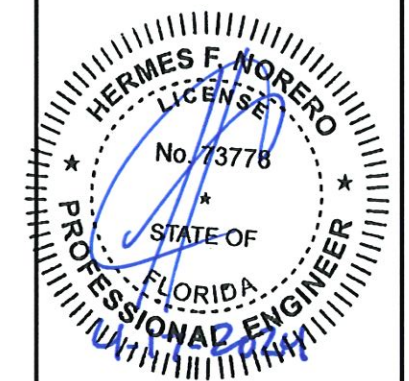

HERMES F. NORERO, P.E.  
FLORIDA P.E. No. 73778  
BUILDING DROPS, INC.  
1900 NE MIAMI CT., STE. 2-15  
MIAMI, FL 33132  
FBPE CERT. OF AUTHORIZATION No. 29578

DATE:	04.11.2024
DWG. BY:	MS
CHK. BY:	HFN
SCALE:	NTS
DWG. #:	UCD002
SHEET:	5

**PRODUCT APPROVED**  
As complying with the Florida Building Code  
NOA-No. **24-0423.01**  
Approval Date: **05/30/2024**  
By: *Manuel Ferraz*  
Miami-Dade Product Control

4/15/2024 6:13 PM

s:\projects\new erra doors\md-23-1236-1 - miami\daade\submittal - impact sidelite and transom\dwgs\ucd002.dwg

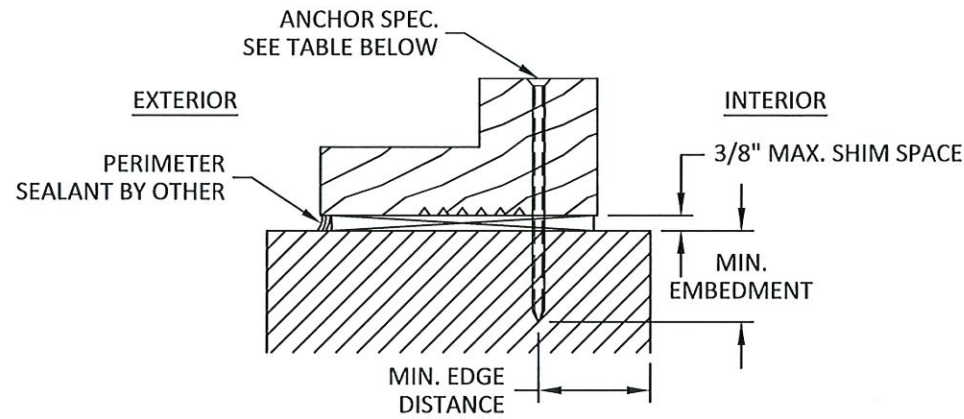

**C**  
**6** INSTALLATION DETAIL

SILL INSTALLATION SHOWN, HEAD & JAMB SIMILAR

**INSTALLATION NOTES:**

- ONE (1) INSTALLATION ANCHOR IS REQUIRED AT EACH ANCHOR LOCATION.
- THE NUMBER OF INSTALLATION ANCHORS DEPICTED IS THE MINIMUM NUMBER OF ANCHORS TO BE USED FOR PRODUCT INSTALLATION OF THE MAXIMUM SIZE LISTED.
- INSTALL INDIVIDUAL INSTALLATION ANCHORS WITHIN A TOLERANCE OF  $\pm 1/4$  INCH THE DEPICTED LOCATION & SPACING IN THE ANCHOR LAYOUT DETAILS (I.E., WITHOUT CONSIDERATION OF TOLERANCES). TOLERANCES ARE NOT CUMULATIVE FROM ONE INSTALLATION ANCHOR TO THE NEXT.
- SHIM AS REQUIRED AT EACH INSTALLATION ANCHOR WITH LOAD BEARING SHIM(S). MAXIMUM ALLOWABLE SHIM STACK TO BE 3/8 INCH. SHIM WHERE SPACE OF 1/16 INCH OR GREATER OCCURS. SHIM(S) SHALL BE CONSTRUCTED OF WOOD OR BETTER.
- FOR MASONRY OR CONCRETE OPENINGS, A 1X WOOD BUCK MAY BE USED (OPTIONAL) AS LONG AS THE MINIMUM EMBEDMENT AND EDGE DISTANCE REQUIREMENTS ARE STILL MET WITHIN THE CORRESPONDING HOST SUBSTRATE. SEE GENERAL NOTE #3 ON SHEET 1 FOR MORE INFORMATION.
- MINIMUM EMBEDMENT AND EDGE DISTANCE EXCLUDE WALL FINISHES, INCLUDING BUT NOT LIMITED TO STUCCO, FOAM, BRICK VENEER, AND SIDING.
- INSTALLATION ANCHORS AND ASSOCIATED HARDWARE MUST BE MADE OF CORROSION RESISTANT MATERIAL OR HAVE A CORROSION RESISTANT COATING.
- FOR HOLLOW BLOCK AND GROUT FILLED BLOCK, DO NOT INSTALL INSTALLATION ANCHORS INTO MORTAR JOINTS. EDGE DISTANCE IS MEASURED FROM FREE EDGE OF BLOCK OR EDGE OF MORTAR JOINT INTO FACE SHELL OF BLOCK.
- INSTALLATION ANCHORS SHALL BE INSTALLED IN ACCORDANCE WITH ANCHOR MANUFACTURER'S INSTALLATION INSTRUCTIONS, AND ANCHORS SHALL NOT BE USED IN SUBSTRATES WITH STRENGTHS LESS THAN THE MINIMUM STRENGTH SPECIFIED BY THE ANCHOR MANUFACTURER.

ANCHOR SCHEDULE				
METHOD	SUBSTRATE	ANCHOR TYPE	MIN. EMBEDMENT	MIN. EDGE DISTANCE
THROUGH FRAME	WOOD: MIN. S.G. = 0.55	#8 WOOD SCREW	1-1/2"	1"
	STEEL: MIN. 18 GA. MIN. Fy = 33 ksi	#8 GRADE 5 SELF-DRILLING/ SELF-TAPPING SCREW	3 THREADS MIN PENETRATION BEYOND METAL	1/2"
	ALUMINUM: MIN. 1/8" THICK MIN. 6063-T5			
	CONCRETE: MIN. f'c = 3000 psi	3/16" ITW TAPCON	1"	1-1/2"
	MASONRY: CMU per ASTM C90 MIN. 2000 PSI		1"	2"



2787 N AIRPORT ROAD #411  
FORT MYERS, FL 33907  
PH: (239) 340-1229

TITLE: SIDELITE & TRANSOM  
INSTALLATION DETAILS AND NOTES  
PREPARED BY: BUILDING DROPS, INC.  
1900 NE MIAMI CT., STE. 2-15  
MIAMI, FL 33132  
PH: (954) 399-8478  
FAX: (954) 744-4738  
WEB: www.buildingdrops.com

REMARKS	BY	DATE

THE INSTALLATION DETAILS DESCRIBED HEREIN ARE GENERIC AND MAY NOT REFLECT ACTUAL CONDITIONS FOR A SPECIFIC SITE. IF SITE CONDITIONS CAUSE INSTALLATION TO DEVIATE FROM THE REQUIREMENTS DETAILED HEREIN, A LICENSED ENGINEER OR ARCHITECT SHALL PREPARE SITE SPECIFIC DOCUMENTS FOR USE WITH THIS DOCUMENT.

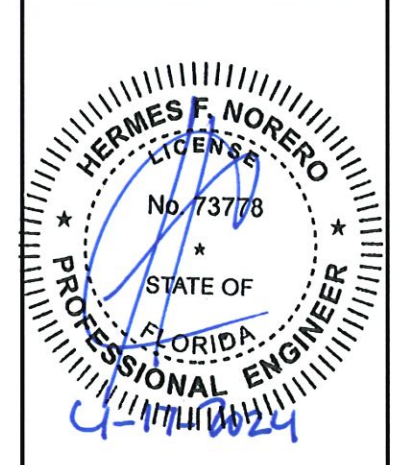

HERMES F. NORERO, P.E.  
FLORIDA P.E. No. 73778  
BUILDING DROPS, INC  
1900 NE MIAMI CT., STE. 2-15  
MIAMI, FL 33132  
FBPE CERT. OF AUTHORIZATION No. 29578

DATE: 04.11.2024  
DWG. BY: MS  
CHK. BY: HFN  
SCALE: NTS  
DWG. #: UCD002  
SHEET: 6

**PRODUCT APPROVED**  
As complying with the Florida Building Code  
NOA-No. 24-0423.01  
Approval Date: 05/30/2024  
By: Manuel Ferrer  
Miami-Dade Product Control





2787 N AIRPORT ROAD #411  
FORT MYERS, FL 33907  
PH: (239) 340-1229

BILL OF MATERIALS				
ITEM #	PART #	DESCRIPTION	MATERIAL	MANUFACTURER
1	-	SIDELITE/TRANSOM FRAME	MAHOGANY	UNIQUE CUSTOM DOOR
2	-	GLASS STOP	MAHOGANY	UNIQUE CUSTOM DOOR

TITLE: SIDELITE & TRANSOM  
BILL OF MATERIALS AND COMPONENTS  
PREPARED BY: BUILDING DROPS, INC.  
1900 NE MIAMI CT., STE. 2-15  
MIAMI, FL 33132  
PH: (954) 399-8478  
FAX: (954) 744-4738  
WEB: www.buildingdrops.com

REMARKS	BY	DATE

THE INSTALLATION DETAILS DESCRIBED HEREIN ARE GENERIC AND MAY NOT REFLECT ACTUAL CONDITIONS FOR A SPECIFIC SITE. IF SITE CONDITIONS CAUSE INSTALLATION TO DEVIATE FROM THE REQUIREMENTS DETAILED HEREIN, A LICENSED ENGINEER OR ARCHITECT SHALL PREPARE SITE SPECIFIC DOCUMENTS FOR USE WITH THIS DOCUMENT.

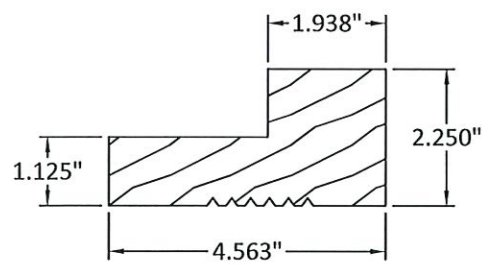

① SIDELITE/TRANSOM FRAME

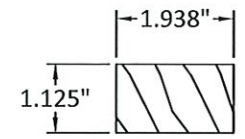

② GLASS STOP

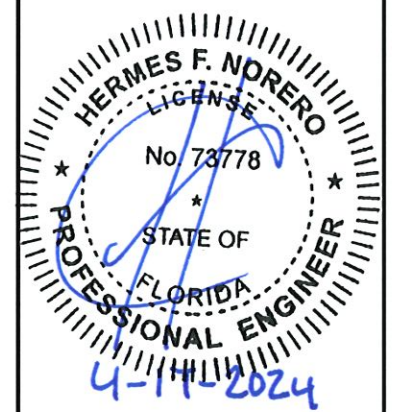

HERMES F. NORERO, P.E.  
FLORIDA P.E. No. 73778  
BUILDING DROPS, INC  
1900 NE MIAMI CT., STE. 2-15  
MIAMI, FL 33132  
FBPE CERT. OF AUTHORIZATION No. 29578

DATE:	04.11.2024
DWG. BY:	MS
CHK. BY:	HFN
SCALE:	NTS
DWG. #:	UCD002
SHEET:	7

**PRODUCT APPROVED**  
As complying with the Florida Building Code  
NOA-No. **24-0423.01**  
Approval Date: **05/30/2024**  
By: *Manuel Perez*  
Miami-Dade Product Control